

Implementation of Brushless DC motor speed control on STM32F407 Cortex M4

Mr. Kanaiya G Bhatt¹, Mr. Yogesh Parmar²

Assistant Professor, Assistant Professor, Dept. of Electrical & Electronics,
ITM Vocational University, Vadodara, Gujarat, India

Abstract — Brushless Direct Current (BLDC) motors, also known as permanent magnet motors find wide applications in many industries due to their higher performance, reliability and ease of control. A new generation of microcontrollers and advanced electronics has overcome the challenge of implementing required control factions, making BLDC motor more practical for a wide range of uses. In this project, BLDC motor circuitry is designed, and develops using 120- degree control with a sensor. In the present project, 3- phase BLDC motor control solution using STM32F407 Cortex M4 as the motor controller, Hall sensors are used to detect the rotor position and close the commutation loop. The main objective of this project is controlling speed of BLDC motor and displays its speed. The speed control of the BLDC motors is very essential. This proposed system provides a very precise and effective speed control system. The user can increase or decrease the speed as per the requirement and the motor will run at that exact speed. Topics discussed include interrupt handling for pulse width modulation (PWM) generation and sensor processing with performance measurement for STM32F407 Cortex M4 microcontroller usage. Implementation of a speed profile (speed Vs. time).

The project is divided into three stages: input, processing and output stage. The input stage consists of entering the required speed through switches. The processing stage provides RPM reference of the motor, by feedback of Hall signal interrupt to the microcontroller in the circuit. The microcontroller develops PWM pulses which are varied with switches to regulate the DC power to the motor such that the desired speed is achieved. The output stage uses a MOSFET being driven by the microcontroller output. A STM32F407 Cortex M4 microcontroller is used with a set of switches to increase or decrease the speed of the BLDC motor. This speed is sensed by the hall sensors and is given to microcontroller which in turn displays it on a LCD display. The above operation is carried out by using PI algorithm and a MOSFET for driving the BLDC motor. This work is aimed at get precise output for speed control using STM32F407 Cortex M4 microcontroller with lower system cost.

Keywords - STM32F407 Cortex M4; Brushless DC motor speed control in open and closed loop.

1. Introduction

This paper describes how to implement a brushless DC motor control in sensor mode using the STM32STM32F407 Cortex M-4 microcontroller. In this document, we will give a description of brushless DC motor theory of operations, we give details about how to control a brushless DC motor in sensor mode and we will also give a short description of the STM32STM32F407 Cortex M-4 boards used in this application report. Simulink model is also discussed with output waveform using a PI algorithm. This application report deals only with BLDC motor speed control application using Hall effect position sensors using commutation sequence.

1.1 BASIC OF BRUSHLESS DC MOTOR:

Brushless Direct Current (BLDC) motors are one of the motor types rapidly gaining popularity. BLDC motors are used in industries such as Appliances, Automotive, Aerospace, Consumer, Medical, Industrial Automation Equipment and Instrumentation. As the name implies, BLDC motors do not use brushes for commutation; instead, they are electronically commutated

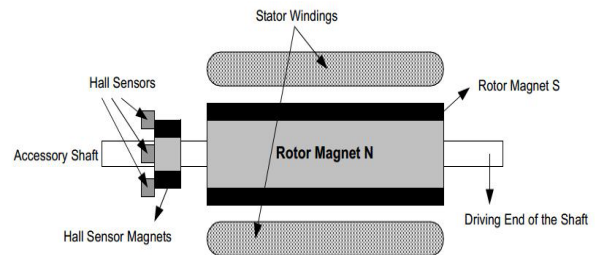

1.2 BLDC Motor Hall Sensor:

Unlike a brushed DC motor, the commutation of a BLDC motor is controlled electronically. To rotate the BLDC motor, the stator windings should be energized in a sequence. It is important to know the rotor position in order to understand which winding will be energized following the energizing sequence. Rotor position is sensed using Hall effect sensors embedded into the stator. Most BLDC motors have three Hall sensors embedded into the stator on the non-driving end of the motor. Whenever the rotor magnetic poles pass near the Hall sensors, they give a high or low signal, indicating the N or S pole is passing near the sensors. Based on the combination of these three Hall sensor

signals, the exact sequence of commutation can be determined. For the estimation of the rotor position, the motor is equipped with three hall sensors. These hall sensors are placed every 120°. With these sensors, 6 different commutations are possible. Phase commutation depends on hall sensor values. Power supply to the coils changes when hall sensor values change. With right synchronized commutations, the torque remains nearly constant and high.

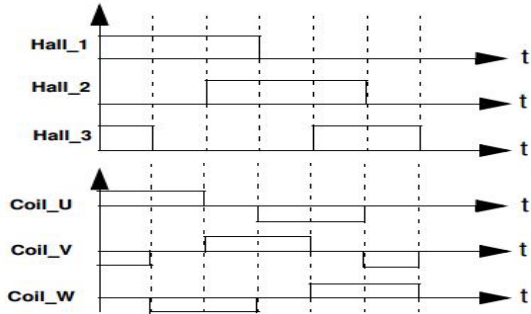

1.3 Phase Commutations:

To simplify the explanation of how to operate a three phase BLDC motor, a typical BLDC motor with only three coils is considered. As previously shown, phases commutation depends on the hall sensor values. . When motor coils are correctly supplied, a magnetic field is created and the rotor moves. The most elementary commutation driving method used for BLDC motors is an on-off scheme: a coil is either conducting or not conducting. Only two windings are supplied at the same time and the third winding is floating. Connecting the coils to the power and neutral bus induces the current flow. This is referred to as trapezoidal commutation or block commutation. To command brushless DC motors, a power stage made of 3 half bridges is used.

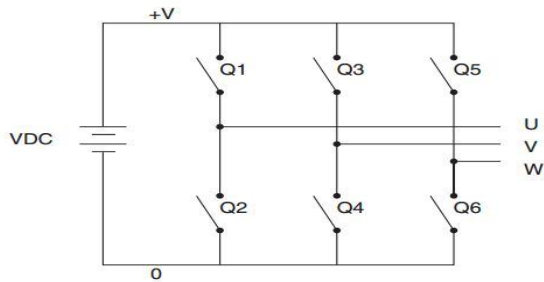

Figure : Half Bridge schematic

Reading hall sensor values indicates which switch should be closed.

Hall Sensors Value (H3 H2 H1)	Phase	Switches
101	U-V	Q1 ; Q4
001	U-W	Q1 ; Q6
011	V-W	Q3 ; Q6
010	V-U	Q3 ; Q2
110	W-U	Q5 ; Q2
100	W-V	Q5 ; Q4

Table: Switches commutation for rotation

1.4 Operation of Brushless DC motor:

Each commutation sequence has one of the windings energized to positive power (current enters into the winding), the second winding is negative (current exits the winding) and the third is in a non-

energized condition. Torque is produced because of the interaction between the magnetic field generated by the stator coils and the permanent magnets of the rotor. In order to keep the motor running, the magnetic field produced by the windings should shift position, as the rotor moves to catch up with the stator field. What is known as “Six-Step Commutation” defines the sequence of energizing the windings. In six-step commutation, only two out of the three Brushless DC Motor windings are used at a time. Steps are equivalent to 60 electrical degrees, so six steps make a full, 360 degree rotation. One full 360 degree loop is able to control the current, due to the fact that there is only one current path. Six-step commutation is typically useful in applications requiring high speed and commutation frequencies. A six-step Brushless DC Motor usually has lower torque efficiency than a sine-wave commutated motor.

2.0 IMPLEMENTATION:

- System Block Diagram:

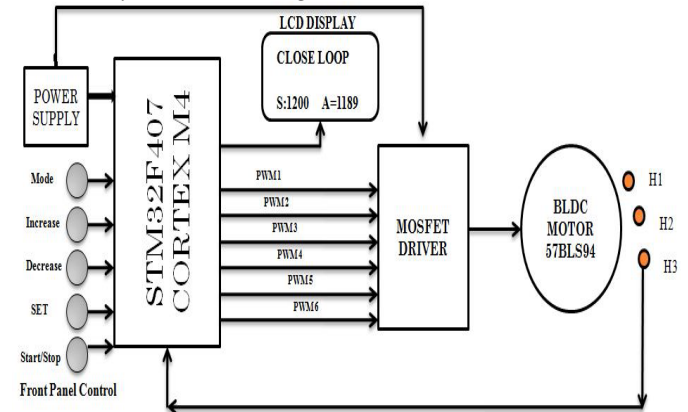

Figure: Basic Block Diagram of Typical Speed control system

2.1 Explanation of Block Diagram

2.1.1 Power Supply:

We have to use two power supply for run the project. First power supply is 5v DC which used to give supply for STM32F407 Cortex M-4. Second power supply is 24V DC which used to give supply for MOSFET driver kit.

2.1.2 Front Level Control :

Mode Selection Switch is used for selecting mode. Here we have used two mode. a) Open loop mode b) Closed loop mode. Speed Up switch is used for increasing duty cycle and speed of BLDC motor. If selection is in Open lopp mode then second switch is used for increasing duty cycle. And if selection is in Close loop mode then second switch is used for increasing speed in rpm. We can see increasing changes of the duty cycle and speed of BLDC motor in LCD display which is interface with our project.

Speed Down switch is used for decreasing duty cycle and speed of BLDC motor. If selection is in Open loop mode then third switch is used for decreasing duty cycle. And if selection is in Close loop mode then third switch is used for decreasing speed in rpm. We can see decreasing changes of the duty cycle and speed of BLDC motor in LCD display which is interface with our project.

Speed-Ref. Set Switch is used to lock the set switch. Which gives command to STM32F407 to consider mode which we have selected by operate switch first.

Start/Stop Switch is used for ON/OFF operation: When we have to start BLDC motor then we have to press switch fifth after selection of Open loop mode or Closed loop mode.

2.1.3 STM32F407 Cortex M-4 controller:

It is used for controlling speed for BLDC motor with generating PWM pulse using hall sensor feedback signal by commutation method. There are power supply, 5 switches, LCD, MOSFET driver and hall sensor feedback signal interface with STM32f407 Cortex M-4. These power supply, 5 switches, Hall sensor feedback signal are input of STM32f407 Cortex M-4 and these LCD, MOSFET driver are output of STM32f407 Cortex M-4. When we choose Open loop mode and press SET button for select open loop mode then we see 50% duty cycle in LCD display and press start button then motor will rotate as 1500 rpm per 50 % duty cycle because of maximum speed of BLDC have 3000 rpm. And if we increase duty cycle from 50% using press switch second then speed of the BLDC motor increasing rotation per minute. And if we decrease duty cycle from 50% using press switch third then speed of the BLDC motor decreasing rotation per minute. If we increasing torque on BLDC shaft then motor speed will reducing their speed because of Open loop configuration. When we choose Closed loop mode and press SET button for select closed loop mode then we see Set speed and Actual speed in LCD display and press start button then motor will rotate as set speed. And if we increase Set speed using press switch second then speed of the BLDC motor increasing rotation per minute. And if we decrease Set speed using press switch third then speed of the BLDC motor decreasing rotation per minute. If Set speed is 1500 rpm same speed rotation of BLDC motor 1500 rpm. If we increasing torque on BLDC shaft then motor speed will remains constant because of closed loop configuration.

STM32f407 Cortex M-4 generating six Pulse Width Modulation signals (PWM) and given to MOSFET driver. STM32f407 Cortex M-4 is received 3 hall sensor signal from BLDC motor output. From that 3 hall sensor signal STM32f407 Cortex M-4 know about motor speed and used for controlling constant motor speed.

2.1.4 MOSFET Driver Board:

MOSFET driver board consist of 6 N-channel power MOSFET (IC IRF840) which is used as 3- phase bridge which is used for rotation 3-phase BLDC motor. There 6 N-channel power MOSFET are connected with 3-phase wire of BLDC motor for given a phase voltage. And MOSFET driver board is controlling by STM32f407 Cortex M-4. STM32f407 Cortex M-4 is given 6 PWM pulses to MOSFET driver board with commutation sequences. From those commutation sequences MOSFET drive motor. MOSFET Driver board I/P comes from STM32f407 Cortex M-4 in the form of pulse and MOSFET driver board O/P is connected with phase wire of BLDC motor.

2.1.5 BLDC Motor (57BLS94):

It is 4 poles, 3-phase Brushless DC motor. It has 3000 rmp maximum speed. Which have interface between MOSFET driver board and STM32f407 Cortex M-4. Motor rotate in respect of MOSFET driver commutation sequence. BLDC motor has internally 3 Hall sensor wire which is connected with STM32f407 Cortex M-4 and 3-phase are connected with 6- N channel power MOSFET which is used for energized 2 coils simultaneously. In BLDC motor Blue, Green and White wire are indicate Hall sensor H1, H2 & H3 respectively. Red and Black wire are indicate +VCC (+5v to +24v DC) and GND. Yellow, Red and Black wires are Phase U, V & W respectively.

3.SYSTEM SCHEMATICS AND CONTROL:

3.1 Circuit Diagram of Our Project:

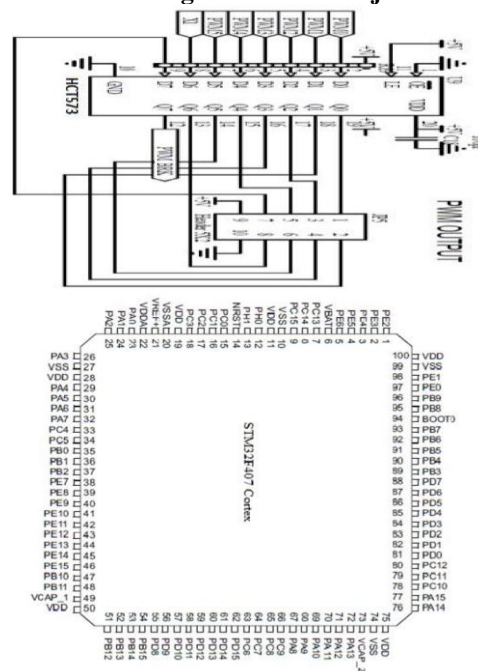

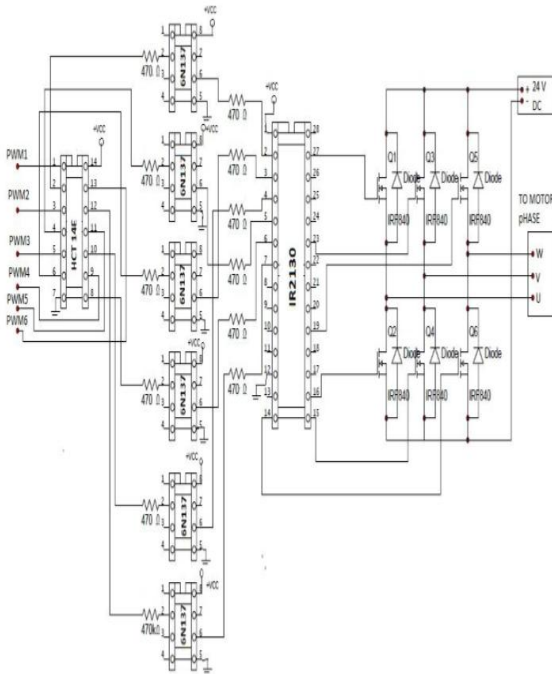
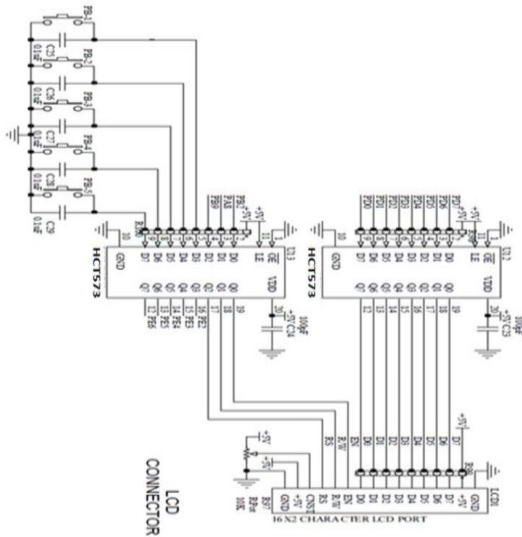

FIG: Circuit Diagram of STM32F407 Cortex M-4 Kit and Driver circuit

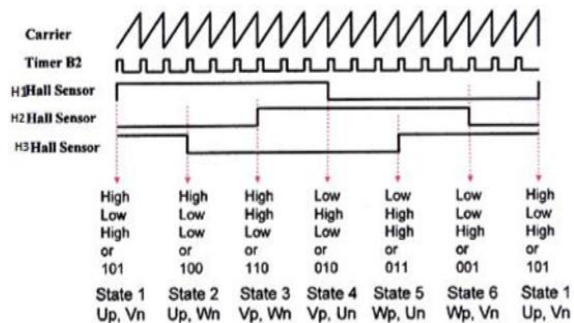

Fig: Six steps changes for 120 deg. input Hall sensor

3.2 Pin diagram STM32F407 Cortex M4:



- Core: Cortex-M4F
- Microcontroller: STM32F407VGT6
- 1MB Flash
- 192KB SRAM
- Package: LQFP100
- I/O pins: 82
- Timers(16-bit): 12
- Advanced Control Timers: 2
- General Purpose Timers: 10
- Basic Timers: 2
- PWM Channels: 6
- ADC(12-bit): 3 (16 channels)
- I2C(TWD): 3
- USART: 4
- SPI: 3 full duplex
- DMA: 2 (8 channels each)
- USB: 1 (2.0 full speed)

3.3 BLDC 57BLS94 motor specification:



Figure: Picture of BLDC 57BLS94 Motor

Motor Specification:

No of Pole	4
No of Phase	3
Rated Voltage.....V	36
Rated Speed.....RPM	4000
Rated Torque.....Nm	0.32
Max peak Torque.....Nm	0.98
Torque constant.....Nm/A	0.061
Terminal Resistance.....Ohm	0.5
Line to Line Inductance.....mH	1.65
B.E.M.F AT NOMINAL SPEED.....Vrms	20.3
Max peak Current.....Amp	15
Length A.....mm	94
Rotor Inertia.....KgM ² x10 ⁻⁶	17.3
Mass.....Kg	1.0

3.3.1 Motor wiring details:

Cable type 1		Function
Red	■	Vcc Hall Sensor +5VDC to +24VDC
Blue	■	Hall A
Green	■	Hall B
White	□	Hall C
Black	■	GND Hall Sensor Ground
Yellow	■	Phase U
Red	■	Phase V
Black	■	Phase W

3.4 MC74HCT573AN: [Non inverting transparent Latch]

Octal 3-state non- inverting transparent Latch with LSTTL compatible inputs. High-Performance Silicon-Gate CMOS the MC74HCT573A is identical in pinout to the LS573. This device may be used as a level converter for interfacing TTL or NMOS outputs to High-Speed CMOS inputs. These latches appear transparent to data (i.e., the outputs change asynchronously) when Latch Enable is high. When Latch Enable goes low, data meeting the setup and hold times becomes latched. The Output Enable input does not affect the state of the latches, but when Output Enable is high, all device outputs are forced to the high-impedance state.

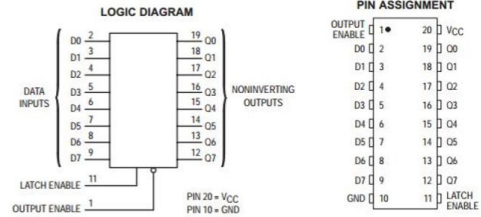

Figure 37: Logic Diagram of MC74HCT573AN Figure 38: Pin Diagram of MC74HCT573AN

FUNCTION TABLE

Inputs		Output	
Output Enable	Latch Enable	D	Q
L	H	H	H
L	H	L	L
L	L	X	X
L	X	X	X

X = Don't Care
Z = High Impedance

Table 8: Function of MC74HCT573AN IC

3.5 IC IRF840: [N-CHANNEL MOSFET]

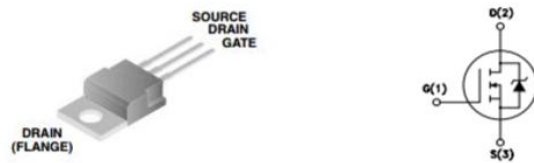

FEATURES:

- 8A, 500V
- Single Pulse Avalanche Energy Rated
- Nanosecond Switching Speeds
- Linear Transfer Characteristics
- High Input Impedance

3.6 IR2130 [3-PHASE BRIDGE DRIVER] DISRIPTION:

The IR2130/IR2132(J)(S) is a high voltage, high speed power MOSFET and IGBT driver with three independent high and low side referenced output channels.

The floating channels can be used to drive N-channel power MOSFETs or IGBTs in the high side configuration which operate up to 600 volts

3.7 HIGH SPEED OPTOCOUPLER 6N137:

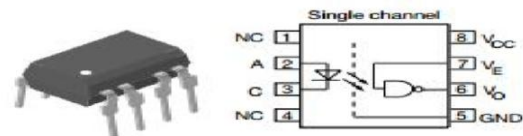
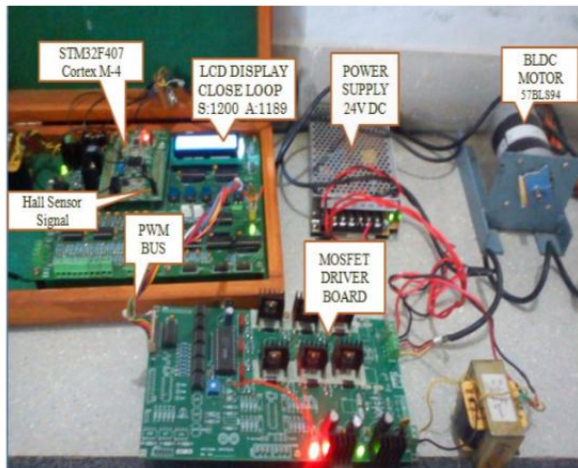

Figure 42: Pinout of 6N137 IC

FEATURES

- High speed: 10 MBd typical
- + 5 V CMOS compatibility
- Guaranteed AC and DC performance over temperature: - 40 °C to + 100 °C
- Meets IEC 60068-2-42 (SO2) and IEC 60068-2-43 (H2S) requirements
- Low input current capability: 5 mA

4.1 Connection of BLDC motor with STM32f4 Discovery Development Board:



4.2: Result:

4.2.1: 6 Switch change-over mechanism using Hall Sensor Feedback:

Observation:

Our calculations will be based on the following formulas: Where, We

consider 3600 RPM and 20-Mhz clock frequency.

Speed (Hz) = Speed (RPM) / 60 = mechanical Hz

$$\text{Mechanical Hz} = 60$$

Electrical Hz = pole pairs * mechanical Hz

$$\text{Electrical Hz} = 120$$

Electrical time period or period = 1/electrical Hz;

$$\text{Period} = 1/120 = 8.3333 \text{ ms} = 8333.3 \mu\text{s}$$

Time tH between two Hall signals = electrical Hz / 6;

$$tH = 8333.3 / 6 = 1388.9 \text{ microseconds.}$$

Counts between two Hall signals = Count Frequency in MHz * time between two Hall signals

Counts = 20 * 1388.9 = 27,778 counts in our example.

When we fix the counting frequency at 20 MHz and the pole-pair equal to 2, the formula can be simplified to give Counts = 100,000,000 / RPM

5. Conclusion:

In this paper it is shown that BLDC motor is a good choice for various applications due to higher efficiency, higher power density and higher speed ranges compare to other motor types. BLDC motor circuitry is designed and develop using 120-degree trapezoidal control with a sensor. In the present project, 3- phase BLDC motor control solution using STM32F407 Cortex M4 as the motor controller, Hall sensors are used to detect the rotor position and close the commutation loop. The main objective of this project is controlling speed of BLDC motor and displays its speed. The speed control of the DC motors is very essential. This proposed system provides a very precise and effective speed control system. The user can increase or decrease the speed as per the requirement and the motor will run at that exact speed.

Topics discussed include interrupt handling for pulse width modulation (PWM) generation and sensor processing with performance measurement for STM32F407 Cortex M4 microcontroller usage.

REFERENCES:

- [1] "Implementing Embedded Speed Control for Brushless DC Motors", Yashvant Jani, Renesas Technology America, Inc., 408-383-7716, yashvant.jani@renesas.com
- [2] "Power Electronics and Variable Frequency Drives Technology and Applications", Edited by Bimal K. Bose, IEEE Press, ISBN 0-7803-1084-5, 1997
- [3] "Motor Control Electronics" Handbook, By Richard Valentine, McGraw-Hill, ISBN 0-07-066810-8, 1998
- [4] "FIRST Course On Power Electronics and Drives", By Ned Mohan, MNP PERE, ISBN 0-9715292-2-1, 2003
- [5] "Electric Drives", By Ned Mohan, MNP PERE, ISBN 0-9715292-5-6, 2003
- [6] "Advanced Electric Drives, Analysis, Control and Modeling using Simulink", By Ned Mohan, MNP PERE, ISBN 0-9715292-0-5, 2001
- [7] "DC Motors Speed Controls Servo Systems including Optical Encoders, The Electro-craft Engineering" Handbook by Reliance Motion Control, Inc.
- [8] "Modern Control System Theory and Application", By Stanley M. Shinnars, Addison-Wesley, ISBN 0-201-07494-X, 1978
- [9] "The Industrial Electronics" Handbook, Editor-in-Chief J. David Irwin, CRC Press and IEEE Press, ISBN 0-8493-8343-9, 1997
- [10] B.K. Lee and M. Ehsani, "Advanced Simulation Model for Brushless DC Motor Drives", 31, 841-868, 2003
- [11] "Microcontroller based control of three phase BLDC motor" Research Article, Journal of Engineering Research and Studies, E-ISSN-0976-7916.
- [12] "Modeling simulation and analysis of a permanent magnet brushless dc motor drive," presented at the IEEE IAS Annual Meeting, Atlanta, 1987.
- [13] R. Krishna, "Electric motor drives" (modeling, analysis and control), low price Edition.
- [14] P. Pillay and R. Krishnan, "Modeling, Simulation and Analysis of a Permanent Magnet Brushless DC motor drive part II: The brushless DC motor drive," IEEE Transactions on Industry application, Vol.25, May/Apr 1989.

WEB SITE:

- [1] "3-Phase BLDC Motor Control with Hall Sensors Using the MC56F8013" Targeting User Guide (<http://freescale.com>) 56F8013BLDCUG, Rev. 1, 11/2005
- [2] "Speed Control of Brushless DC Motors-Block Commutation with Hall Sensors" User's Guide, (www.microsemi.com/soc/support/search/default.aspx).
- [3] "Motor control and Drive" <http://www.microchip.com/pagehandler/en-us/technology/motorcontrol/motor-types/bldc.html>
- [4] <http://www.mathworks.in/help/physmod/elec/examples/brushless-dc-motor.html>
- [5] <http://www.youtube.com/watch?v=5GTQI9aG8U0>
- [6] <http://ctms.engin.umich.edu.php=MotorSpeed§ion=SimulinkModeling>
- [7] http://www.en.pudn.com/downloads161/doc/detail727719_en.htm
- [8] http://eprints.uitm.edu.my/3602/1/MOHAMADFAUZI_BIN_OMAR_07_24.pdf
- [9] <http://www.mathworks.in/help/robot-axis-control-brushless-dc-motor-drive.html>
- [10] <http://www.liveieeeprojects.com/bldc-motor-speed-control-with-rpm-display>
- [11] <http://karthikpatnaik.blogspot.in/bldc-speed-control-matlab-simulink.html>