

# The Production of Green sustainable Fuel From Castor Oil

Assistant prof. Dr.Hassan Abdul-whab Anjel <sup>#1</sup> and <sup>#2</sup>Ribwar Kermanj Abdulrahman

<sup>1#</sup> Environmental Engineering Department, College of Engineering, Knowledge University, Erbil, Iraq

<sup>2#</sup> Department of Chemical Engineering, Faculty of Engineering, Koya University, University Park, Kurdistan Region of Iraq

**Abstract** ( Size 10 & bold &Italic)— *The demand of energy around the Worldwide has been dramatic. Moreover, fossil fuel emits huge quantities of toxic gases that contribute in global warming phenomenon. Thus, many countries are seeking to adopted bio fuel as alternative of traditional petroleum fuels. The using of biodiesel fuel may contribute in minimizing global warming phenomenon. Moreover, it posses several advantages over petroleum diesels for example, nontoxic and readily biodegradable. Furthermore. It has been observed that the castor oil plant grows wild in Koya region in Iraqi Kurdistan. Indeed, castor oil may consider a quite reliable source to produce biodiesel. Indeed, it can produce in huge quantities in Iraqi Kurdistan region. Thus, this work aims to produce biodiesel from castor oil by using transesterification reaction. Moreover, this work has also adopted process optimization to find out the optimum operating conditions for the process for example, methanol to oil ratio. Furthermore, several tests have been applied on the produced fuel on specific gravity and flash point.*

**Keywords:** Biodiesel, Renewable energy, Process optimization, Transesterification process.

## I. Introduction

Many oil reservoirs are depleted every day. Moreover, petroleum diesel engines are emitting significant amounts of greenhouse gases every moment that contribute directly in global warming phenomenon [1]. Therefore, many researchers and oil companies tried to discover a new energy sources that can be used as an alternative fuel for various uses [2,3]. In fact, biodiesel has received huge attention in the world to be used as alternative fuel for diesel engines. Moreover, it possesses several advantages over petroleum diesel for example, reduces the demand of petroleum fuels, nontoxic and reduces the global climate changes and environmental pollution. Biodiesel fuelled engines produce less CO, HC and particulate emissions than petroleum diesel fuelled engines. Indeed, biodiesel could be used directly in some specific diesel engines [4]. However, it should be blended with petroleum diesel, if it required to be used in normal diesel

engine. As a result, biodiesel blends can be used in diesel engines without any major modification. Many researchers have indicated that the biodiesel is quite close to diesel fuel. Indeed, biodiesel could be produced from vegetable oils and animal fats as well. Moreover, almost biodiesel is produced from rapeseed oil and waste cooking oil [5]. Indeed, it is quite important to use low cost feedstock to reduce the production cost of the biodiesel. Moreover, the use of vegetable oil leads to shortage of food while use of animal fat for human consumption is a health hazard [5]. Biodiesel could be produced by transesterification reaction that is a three step reaction which converts the initial triglycerides into a mixture of fatty acid methyl ester and glycerol in the presence of a catalyst usually homogeneous or heterogeneous [6]. Indeed, there are many catalysts can be used for this purpose for example, alcohol such as, ethanol. These catalysts can be used in the transesterification reaction [1]. Furthermore, other types could be utilized in this reaction for example, sulphuric acid, hydrochloric acid and sodium hydroxide [1]. In fact, it has been observed the Castor plant in Iraqi Kurdistan region is grown in wild fields in many cities of Iraqi Kurdistan, Sulaymaniyah, Ranya and Koya as shown in fig.1. The observed wild castor plant are produced considerable amounts of Castor seed that can be invested to produced Castor oil and biodiesel. Thus, it is quite recommended that to achieve more studies about mentioned Castor plant.

Castor seed can be considered one of the most important oilseed crops and it is contained considerable amounts of oil. Castor oil is pale yellowish or colorless oil which extracted from the Castor seeds of the castor plant. Castor plant is cultivated around the world cause of the commercial importance of Castor oil [8]. Castor oil is used in manufacturing of several chemical industrial for example, greases and lubricants, coatings, cosmetics and pharmaceuticals. Indeed Castor plant grows well under hot and humid conditions and has a growing period about 4 to 5 months. The Castor seed contains considerable amounts of oil [8]. Table 1 shows Castor oil properties.



Figure 1: Wild castor plant in Koya city in Iraqi Kurdistan region.

## II. Research methodology

The castor oil obtained at a local market. Moreover, the experiment has been accomplished in a laboratory that utilized a 250 ml flask. The flasks were kept in a water bath maintained at 60°C. The transesterification reaction has been adopted to produce the biodiesel from castor oil. The KOH catalyst has been dissolved with the required amount of methanol. Then liquid has been added to the oil in a specific flask. The reaction has been achieved at 60°C and for 30 min at 700 rpm. Moreover, figure (2) shows the hotplate magnetic stirrer that been adopted in the process. Then, the reaction was finished for oil, and then separator funnel has been used to separate the reaction product into two layers. Figure (3) shows the separator funnel. Finally, two materials have been separated from each other. Table 1 included the castor oil properties.

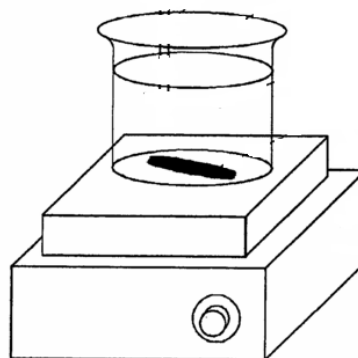

Figure 2: Hotplate Stirrer.

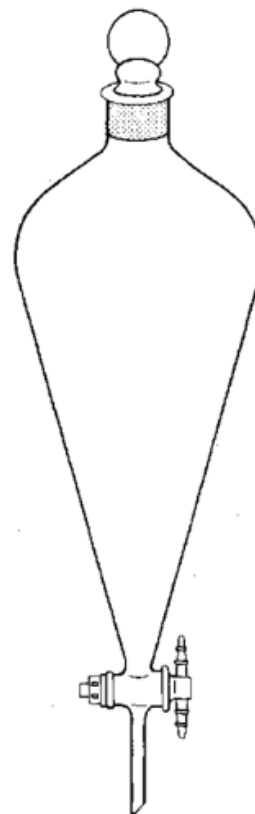

Figure 3: Separator funnel.

Table 1: castor oil Properties [8].

Property	Value
Specific gravity 25/25 °C	0.961 to 0.963
Melting point °C	-18 to -10
Iodine Number °C	82-90
Saponification Number	176-190
Iodine value	103 to 128

## III. Results and discussion

Biodiesel from the castor oil has been successfully produced by using transesterification reaction process. The produced biodiesel has been subjected to several laboratory tests for instance,

viscosity and flash point. Table 2 shows the produced biodiesel testes results.

Table 2: The produced biodiesel properties.

Property	Produced biodiesel
Density (kg/m <sup>3</sup> )	915
Fire Point °C	201
Flash point °C	177
Cetane index	51

This research is also studied the effects of methanol: oil molar ratio and reaction time on the biodiesel yield from castor oil. Indeed, the relationship between the biodiesel yield and the reaction time has been studied at several methanols: Oil ratio for instance, 3:1 and 7:1. The reaction has been maintained 60 °C. Figure (4) shows the relationship between biodiesel yield % and reaction time for several methanols: oil ratios. It seems that the methanol: oil ratio has huge effects of the biodiesel yield. It seems that the optimum biodiesel yield has been achieved in this optimization process is (84%) of biodiesel at methanol: oil molar ratio about 7: 1 and reaction time about one hour.

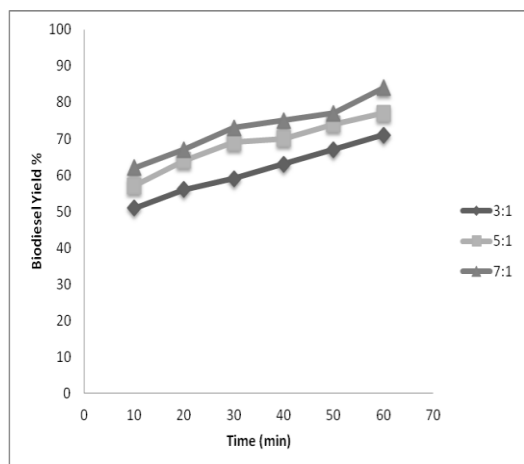

Figure 4: The relationship between biodiesel yield % and reaction time for several methanol oil ratio.

#### IV. Conclusion

In conclusion, Biodiesel has many advantages over traditional petroleum diesel. This work is attempted to produce reliable biodiesel from castor oil. It can be argued that it is possible to produce biodiesel from castor oil by adopting transesterification method. The process optimization is also achieved the optimal alcohol: oil ratio. It can be argued that adopting methanol/ oil ratio about 7:1 could achieved productive biodiesel yield about 84%. However, it is also quite recommended that to achieve more studies and process optimization

before installing biodiesel plant for commercial production.

#### V. REFERENCES

- [1] Ribwar Kermanj Abdulrahman "Effect of Reaction Temperature on the Biodiesel Yield from Waste cooking Oil and chicken fat", International Journal of Engineering Trends and Technology (IJETT), V44(4),186-188 February 2017. ISSN:2231-5381. www.ijettjournal.org. published by seventh sense research group.
- [2] Abdulrahman R. K., Omar T.J. The Studying of Production Biodiesel From Poultry Fats As An Alternative Fuel Than Traditional Petroleum Diesel Fuel, International Journal of ChemTech Research, 2015, 7(4): 1739-1742.
- [3] Ali, J., Abdulrahman, R., Zangana, M., Ali, J., Abdulrahman, R. and Zangana, M. (2017). The Production of Biodiesel from Animal Tallow to be Used for Electric Generators: A Case Study. [online] Article.sapub.org. Available at: <http://article.sapub.org/10.5923.j.ep.20150501.03.html> [Accessed 14 Mar. 2017].
- [4] Janga, M., Kimb, D., Parkb, S.,and Leeb, J., Kima, S. (2012) 'Biodiesel production from crude canola oil by two-step enzymatic processes', Renewable Energy. 42 (1). PP. 99-104.
- [5] Ahmad, M. (2012) Practical Handbook on Biodiesel Production and Properties. Boca Raton: CRC Press.
- [6] Shin, H., Lim, S., Kang, S., and Bae, S. (2012) 'Statistical optimization for biodiesel production from rapeseed oil via transesterificaion in supercritical methanol', Fuel Processing Technology. 98 (2). PP. 1–5.
- [7] Anon, (2017). [online] Available at: [http://file.scirp.org/pdf/LCE20110100005\\_63987199.pdf](http://file.scirp.org/pdf/LCE20110100005_63987199.pdf) [Accessed 14 Mar. 2017].
- [8 ] Bassam, N. (2010) Handbook of Bioenergy Crops: A Complete Reference to Species, Development and Applications. Oxford: Routledge.