

# Design and Implementation of SMS-Based Industrial/Homes Gas Leakage Monitoring & Detection Alarm System

Onengiye M. Georgewill <sup>#1</sup>, Chukwunazo J. Ezeofor <sup>\*2</sup>

<sup>#</sup> Rector, Ken Saro-Wiwa Polytechnic Bori, Rivers State, Nigeria

<sup>\*</sup> Department of Electronic & Computer Engineering, University of Port Harcourt, Rivers State, Nigeria

**Abstract-** This paper presents the design and implementation of SMS based Industrial/Homes Gas Leakage Monitoring and Detection Alarm System (SMS-GLMDAS). Gas leakage is a major concern at homes, offices, industries etc. Many homes and industries had fallen victims of inferno due to unknown Gas leakage at a hidden point. This is dangerous and requires high security to avoid life and property being destroyed. One of the preventive measures to avoid the danger associated with gas leakage is to install a gas leakage detector at vulnerable locations, hence SMS-GLMDAS is proposed. The system is designed to prevent loss/death to occur through gas leakages and hence promote safety of life and property. The system consists of hardware and software; all were designed, built, programmed, and integrated. The program codes written using Embedded C-language and system test carried out to ensure optimum performance. The time it takes the user to receive an SMS from the system control unit when Gas leakage is detected is also checked and tested for accuracy to ensure prompt delivery of the early warning message of the system.

**Keywords-** ATmega328 Microcontroller, Gas sensor, GSM/GPRS Shield, Alarm system, SMS-GLMDAS, Arduino Sketch\_Mar28a IDE, Short Message Service (SMS)

## I. INTRODUCTION

Liquefied Petroleum Gas (LPG) is first produced in 1910 by Dr. Walter Snelling as a mixture of commercial propane and commercial butane having saturated as well as unsaturated hydrocarbons which is highly flammable chemical. It is an odourless gas to which Ethane oil is added as powerful odourant so that leakage can be easily detected [1]. Liquefied Petroleum Gas (LPG) is flammable mixtures of hydrocarbon gases used as fuel in homes/Industries filled in cylindrical vessels of various capacities for heating appliances, cooking equipment, and vehicles. Because of the versatile nature of LPG, it is used for many needs such as domestic fuel, industrial fuel, automobile fuel, heating, illumination etc. and the demand for LPG is on an increase day by day. The liquefied petroleum gas is finding wide usage in our

homes, industries and in automobiles as fuel because of its desirable properties which include high calorific value, produces less soot, produces very less smoke and does not cause much harm to the environment.

LPG burns to produce clean energy; however there is a serious threat about their leakages. The gases being heavier than air do not disperse easily and may lead to suffocation when inhaled; also the leaked gases when ignited may lead to explosion. LPG has become a widespread energy source because it's highly combustible, which means that it can produce large amounts of heat when small amount is burnt [2]. Consequently, a natural gas leaks can increase the risk of fire and explosion since it spreads quickly and combusts easily. An electrical spark or fire source can set this off if you have a leak in your house. The number of deaths due to the explosion of gas cylinders has been increasing in recent years.

Before the development of electronic household gas detectors in the 1980s and 1990s, gas presence was detected with a chemically infused paper that changed its color when exposed. Since then, many technologies and devices have been developed to detect, monitor, and alert the leakage of a wide array of gases. Today, sensors have a high sensitivity to a wide gases variety; they are very compact in sizes and have significantly reduced their power consumption to adapt better portable solutions [3]. Building a system with a gas sensor is not as easy as it could appear. As an example the internal elements of a sensor such as heater and gas sensitive resistors have to be constantly kept under control to avoid failures leading to a wrong alarm indication. The detector can be used to trigger alarms if a specified concentration of the gas or vapour is exceeded. This can provide an early warning of a problem and help to ensure people's safety. However, a detector does not prevent leaks occurring or indicate what action should be taken

LPG and Gas sensors are employed in a wide range of applications in the fields of safety, health, and instrumentation. Common examples are domestic or commercial alarms for explosive and toxic gases or in automotive application as gas leakage detectors for LPG powered cars and exhausts detectors inside any fuel powered truck or car. Such sensors, nowadays, are found also in applications involving air quality control systems and pollution monitoring [4].

Some people have low sense of smell, may or may not respond on low concentration of gas leakage. In such a case, gas leakage security systems become an essential and help to protect them from gas leakage accidents.

This is a detailed work on embedded system for hazardous gas detection and alerting the user by sending an SMS. In order to provide high accuracy, gas sensor MQ-9 has been used and alarm is activated and message is sent via SMS when leakage is found at home or industry.

## II. RELATED WORK

The researched related works are not limited to:

- a. Internet based Monitoring using Servers, modems, etc. with different approaches: GPRS Internet monitoring is one of the common approaches for remote monitoring. Many researchers have worked in field of Internet based remote monitoring. Peng Liu et al. developed model of web services based email extension for remote monitoring of gas leakages using embedded systems which integrates web services like emails [5]. It uses a general purpose email messaging framework to connect devices and manipulators. This low cost model fits for systems with low connection bandwidth, small data transportation volume, non-real time monitoring of gas leakages and remote meter-reading of leakage consecration.
- b. GSM-based communication protocols using GSM Modem or in combination with Internet technologies: Khoyal et al. proposed SMS based system for controlling of home appliances (which includes gas cylinders and electric heater) remotely and providing security when the user is away from the place. Home appliance control system (HACS) consists of PC which contains the software components through which the appliances are controlled and home security is monitored and GSM Modem that allow the capability to send and receive SMS to and from the system. The communication with the system takes place via RS232 serial port [6].
- c. Monitoring using Wireless Sensor Networks, Bluetooth, Wi-Fi, Zigbee and RF: Wijetunge et al designed a general purpose controlling module with the capability of controlling and sensing gas leakage and fire simultaneously for house and industrial safety [7]. The communication between the controlling module and the remote server is done using Bluetooth technology. The server can communicate with many such modules simultaneously. The controller is based on ATmega64 microcontroller and Bluetooth communication TDK Blu2i (Class 1) module which provides a serial interface for data communication. The designed controller was deployed in a home automation application for a selected set of electrical appliances.

## III. METHODOLOGY

The SMS-GLMDAS system design is achieved by using top-down approach. The hardware module is designed first as indicated in the block diagram of fig.1. The software module is developed using C-language. The design focuses mainly on module integration and interface of the system. The system architecture has different five functional units and each unit requires input to generates desired output.

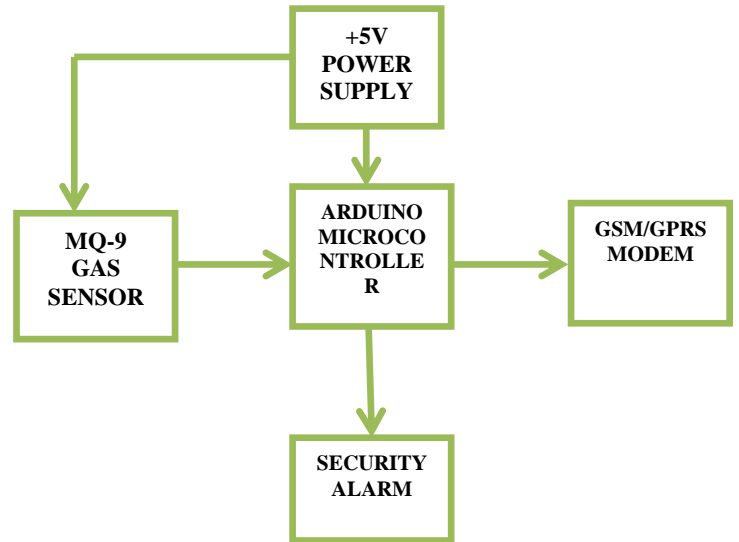

Fig.1: SMS-GLMDAS S block diagram

1) **Power Supply Unit:** Power supply is a device used to supplies power to all the chips and components of the system circuit board. The system requires +5V direct current (DC) supply as the operating voltage for Arduino ATmega328 Microcontroller, MQ-9 Gas sensor, security alarm and GSM/GPRS Modem. A 18V DC battery is used to capture the required supply voltage of the system. The voltage is regulated using LM7805 regulator for constant +5V DC as shown in fig.2.

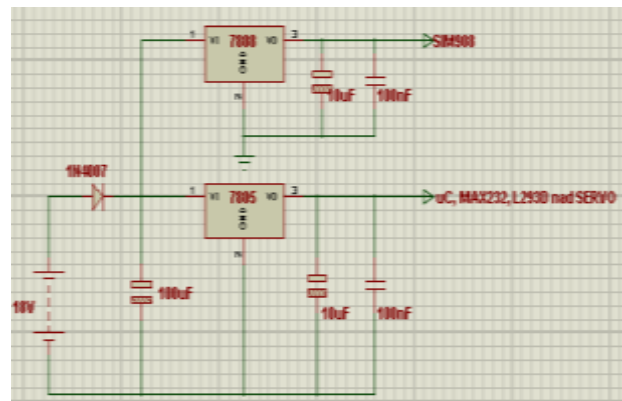

Fig.2: Regulated +5v DC supply circuit

When 18V DC battery is connected as shown observing the polarity on the circuit, voltage is transferred to the breadboard and regulated using LM7805 regulator which maintains constant of +5V to the circuit.

2) **MQ-9 Sensor unit:** The most common gas leakage at homes/industries are carbon monoxide and liquefied petroleum gas (flammable gases), MQ-9 gas sensor as shown in fig.3. is deployed to detect any gas leakages and report to the control unit of the system.



Fig.3: MQ-9 Gas Sensor

MQ-9 is a Semiconductor Sensor designed to detect carbon monoxide/Combustible gas and it does detection by the method of cycle high and low temperature. It detects carbon monoxide when low temperature heated by 1.5V is supplied. The sensor's conductivity is higher along with the gas concentration rising at high temperature (heated by 5.0V). It detects Methane, Propane combustible gas and cleans other gases adsorbed under low temperature. The sensor could be used to detect different gases containing carbon monoxide and combustible gases, at low cost and suitable for different applications.

### 3) **Arduino ATmega328 Microcontroller :**

The Arduino Uno is an embedded board with 14 digital input/output pins (of which 6 can be used as pulse width modulation outputs), 6 analog inputs, a 16 MHz crystal oscillator, ATMEGA 328 , a USB connection, a power jack, an In-circuit System Programmer header, and a reset button as shown in fig.4. It contains everything needed to support the microcontroller; simply connect it to a computer with a USB cable or power it with an AC-to-DC adapter or battery to get it started. The Arduino Uno board differs from all preceding embedded boards in that it does not use the FTDI (Future Technology Device International) and USB-to-serial driver chip. Instead, it features the ATMEGA328 programmed as a USB-to-serial converter. The Uno is the latest in a series of USB Arduino boards and the reference model for the Arduino platform; for a comparison with previous versions [8].



Fig.4: Arduino Uno board with ATmega328 Controller

The Arduino ATmega328 has 32 kB of flash memory in which 0.5 KB is used for the boot loader. It also has 2 KB of static random access memory (SRAM) and 1 KB of Electrical Erasable Programmable Random Only Memory (EEPROM) which can be read and written with the EEPROM library.

The Arduino Uno has a number of facilities for communicating with a computer, another Arduino, or other microcontrollers. The ATmega328 provides UART TTL (5V) serial communication, which is available on digital pins 0 (RX) and 1 (TX). An ATmega16U2 on the board channels this serial communication over USB and appears as a virtual com port to software on the computer. The '16U2 firmware uses the standard USB COM drivers, and no external driver is needed. However, on Windows, .inf file is required. The Arduino software includes a serial monitor which allows simple textual data to be sent to and from the Arduino board. The RX and TX LEDs on the board will flash when data is being transmitted via the USB-to-serial chip and USB connection to the computer (but not for serial communication on pins 0 and 1) [9].

4) **SIM900 GSM Modem Unit:** SIM 900 is for frequency GPRS/GSM modem and an ultra- compact and reliable wireless modem. It is a breakout board and sim900 quad band GPRS/GSM modem as shown in fig.5. It can communicate with microcontroller via MAX232 driver, activated using AT commands. This module supports software power on and reset. The GPRS is configured and controlled via its universal asynchronous receiver transmitter, UART using simple AT commands.



Fig.5: Sim900 GSM Modem

5) **Security Alarm Unit:** The audio sound system is a transducer that converts an electrical signal into acoustic energy. The buzzer produces sound based on application of an electrical signal. The



buzzer as shown in fig.6 can be used to alert a user of an event corresponding to a switching action, counter signal or sensor input. They are also used in alarm circuit. The buzzer produces a same noisy sound irrespective of the voltage variation applied to it. It consists of crystals between two conductors. When a potential is applied across these crystals, they push on one conductor and pull on the other. This, push and pull action, results in a sound wave. Most buzzers produce sound at the range of 2 to 4 kHz. When a gas leakage is sensed, the microcontroller sends signal to the buzzer and it sounds an alarm.



Fig.6: Buzzer/Alarm

**6) SMS-GLMDAS Design & Operations:** A cost-effective gas leakage detection and alarming monitoring system was proposed, designed and successfully implemented in this research work. The system has five units namely power supply, gas detector, controller, GSM modem and security alarm. Test was conducted on each of the unit to verify its working capability. From the test, gas detector senses the presence of gas leakage and sends the signal to the controller through its analog input port. The ATmega328 Microcontroller picks the signal, processes it and sends SMS alert through GSM Modem to the service station or to the owner of the premises which reads ‘Gas Leakage at Premises (Attention Required)’ within two seconds. Also the security alarm is activated which would attract attention of nearby to take action in order to protect property from dangerous inferno. The SMS-GLMDAS system responds to emergency very effective. The circuit showing all the modules mentioned above is shown in fig.7.

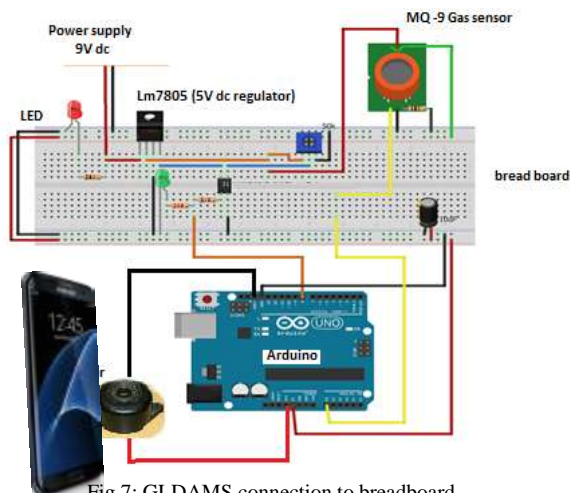

Fig.7: GLDAMS connection to breadboard

**7) How SMS-GLMDAS circuit module works?:**

When the system is switched ON, the default inbuilt LED on the board blinks that indicates power has been supplied to the board. The system initializes the sensor, security alarm and GSM modem through the uploaded sequence of written codes. The MQ-9 sensor keeps monitoring gas leakage and when it detects, it sends signal to the Arduino ATmega328 microcontroller which processes the signal, activate the security alarm and send SMS alert to the owner through the SIM900 GSM modem. The alarming and monitoring continues until action is taken.

**8) SMS-GLMDAS Programming Codes:**

Having designed, simulated and built the hardware, the Arduino chip is as good as nothing if it has no software to drive the microcontroller. The software development was done using embedded C programming language in Arduino IDE environment as shown in fig.8. The choice of embedded C language is because of its high level language, easy to use and understand. The codes are written, compiled and uploaded in Arduino ATmega328 microcontroller.



Fig.8: Arduino IDE plus Embedded C- language

**9) System Flow Chart:**

The system program is written using the flow chart shown in fig.9. The system first initialized, and reads input sensor. If the gas is leaking, the sensor detects and sends signal to control unit which then activate alarm and sends sms to the user. If the gas is not leaking, the system continues to check the sensor until it senses gas leakage.

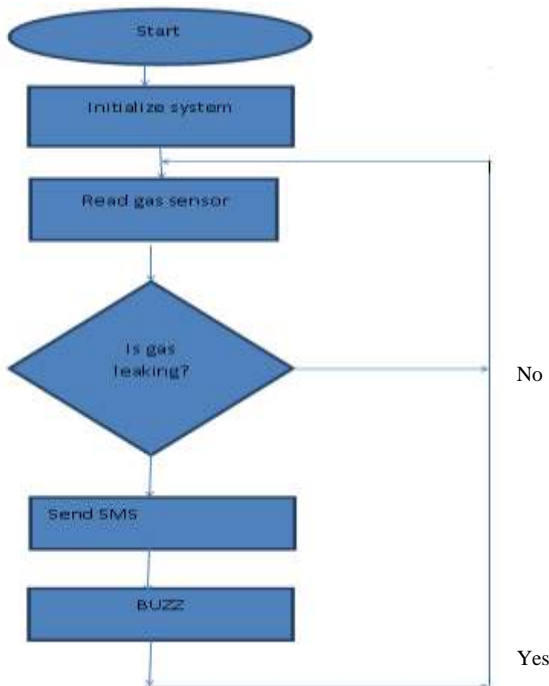

Fig.9: Gas leakage and alarm system flow chart

**IV. TEST AND RESULT**

The design and simulation of the SMS-GLMDAS takes two major parts which are hardware and software as earlier explained. In hardware section, power supply unit was designed, built and tested with multimeter to ensure constant supply of +5V DC to the system. The MQ-9 sensor was tested by connecting the output pin to the analog input port of the ATmega328 controller. The cigarette lighter gas was used to test the performance of the gas sensor and security alarm triggered by the controller when the gas is detected.

The SIM 900 GSM modem was connected properly and AT commands codes that communicate with the controller were written and uploaded in the ATmega328 through the Arduino sketch\_mar28a Integrated Development Environment. The designed SMS-GLMDAS, which is meant to detect gas leakage and alert users through alarm action (by buzzer) and send SMS through GSM MODEM, was tested as shown in fig.10a. Physical testing was done to ensure that Gas leakage detection alarming triggers the controller to send message to the Gas owner’s mobile phone for preventive action to be taken in order to avoid any further hazardous effect in the home/industry. The procedures used in the testing of the SMS-GLMDAS are as follows:

- i. Press the “ON” power button of the Designed system.

- ii. Hold down the gas valve of the lighter to release gas.

The gas sensor senses a change in the ions in the air caused by gas presence passes the signal to the Arduino microcontroller which triggers the buzzer and sends SMS to the default phone numbers (the numbers is incorporated in the Arduino microcontroller through program). The user of the phone reads the message ‘Gas Leakage (attention required)’ and takes proactive actions as shown in fig.10b.



Fig.10a: Testing of the Gas leakage detection and alarming system

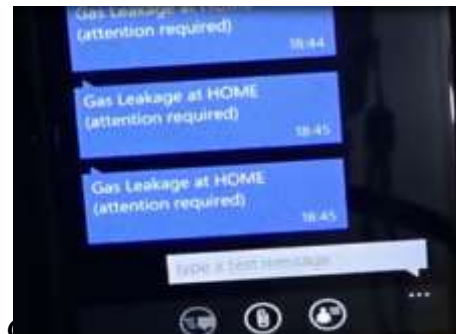

Fig.10b: Alert message sent to a GSM to notify user of Gas leakage detected

**TABLE I : GAS LEAKAGE DETECTION TIME**

Experiment	Time in Seconds
1	1.4
2	1.2
3	1.6
4	1.7
5	1.3
Average	1.44

The plotted graph of time version Gas leakage is shown in fig.11 and is done using MATLAB.

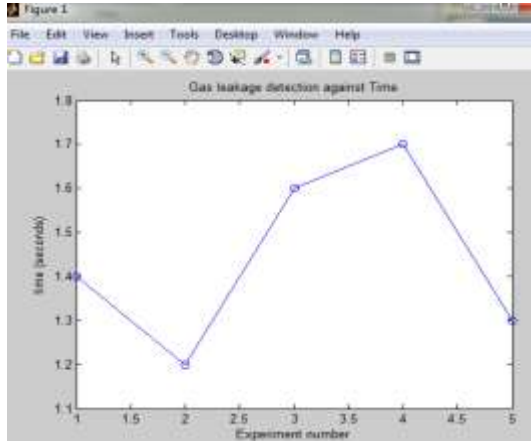

Fig.11: A graph of Gas leakage Detection against t

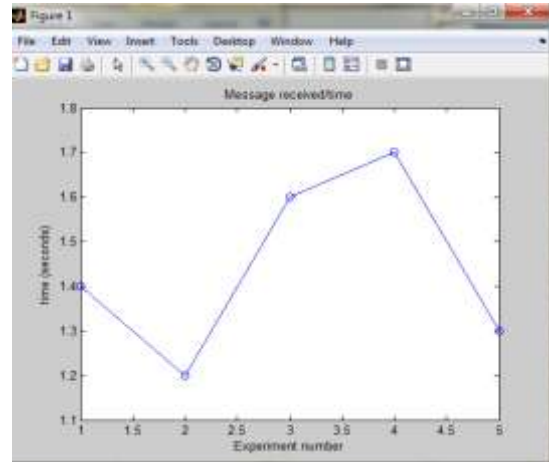

Fig.12: A graph plot of message received against time

The results of the experiment indicate that MQ 9 sensor detects the occurrence of gas leakage within an average time of 1.44 seconds. From the plotted graph of gas leakage detection against time, it can be observed that the time of detection changes with each experiment. This is due to the condition surrounding the sensor. Temperature change and humidity can also affect the time of detection. However the deviation is significantly very low and does not affect the operation of the system.

2) **GSM MODEM Test and Result:** The Experiment performed to check for SMS response (GSM MODEM) and the time when the SMS (message) is delivered to the recipient is captured as shown in table 2.

TABLE 2: TIME MESSAGE WAS RECEIVED

Experiment	Time in Seconds
1	35
2	30
3	43
4	55
5	32
Average	39

The time of receiving a message depends on the time of detection. That is, the system detects that there is gas leakage before a message is sent. From the graph of message received against time as shown in fig.12, the time each message was received in each experiment varies. This is due to irregularities in the operations of our GSM networks. The message was received within an average time 39 seconds after gas leakage was detected. The plot was done using MATLAB.

## V. CONCLUSION

This system is designed and implemented using MQ-9 Gas sensor and embedded Arduino microcontroller. Test was conducted to verify if the sensor can trigger the controller when it senses presence of gas through ionization. From the test, gas detector senses the presence of gas leakage and an SMS alert sent to the service station or to the owner of the premises .The message is sent within some seconds delay due to network and can be sent anywhere in the country for further action to be taken to stop gas leakage at its initial state. The embedded message it would always send is ‘Gas Leakage At Home (Attention required)’. Using this method, the Buzzer sounds an alarm incase there is occurrence of the fire incident. This has proved that the system like this is a beneficial and effective type for homes/industries. However, a cost-effective gas leakage detection and alarming system was proposed, designed and successfully implemented.

## ACKNOWLEDGMENT

We would like to express our deepest appreciation to God for making this paper a reality. Also to IJETT editors, for their humble commitment and prompt response in attending to Engineering Journal papers any time. Special thanks to our family for all their moral support and encouragement throughout the paper work.

## REFERENCES

- [1] Xiao Liu, Sitian Cheng, Hong Liu, Sha Hu, Daqiang Zhang and Huansheng Ning, a survey on Gas sensing Technology school of Electronic and information Engineering, Beihang university, Beijing 100191, China 2012.
- [2] Meenakshi.P Vidya , S.Abinaya, G.Geetha Rajeswari And N.Guna, Automatic Lpg Leakage Detection And Hazard Prevention For Home Security, Proceeding Of 5th National Conference On Vlsi, Embedded, And Communication & Networks On April 17, 2014 issn: 2320-0790 2014.

- [3] Al-li, member, IEEE & M. Al-rousan, Java-Based Home Automation System R.' IEEE transaction on consumer electronics, vol.50, no. 2, may 2004.
- [4] Mohamad Fadli Bin Ismail, Wireless Gas Leaking Detector Universti Teknikal Malaysia Melaka, Malaysia 2009.
- [5] Arduino Microcontroller Atmega7805 Datasheet, Retrieved From <http://www.arduino.cc>\_2015.
- [6] Sunithaa.J, Sushmitha.D, Embedded Control System For Lpg LeakageDetection And Prevention, International Conference On Computing And Control Engineering (ICCCE 2012), 12 & 13 April, 2012
- [7] National institute of health, What you need to know about Natural Gas detectors 2004  
<http://www.nidcd.nih.gov/health/smelltaste/gas>.
- [8] Khiyal Msh, Khan A, Shehzadi E, SMS based wireless Home Appliance Control System (HACS) for automating appliances and security. Issues in Informing Science And Information Technology. 6:887-894 ,2009.
- [9] Wijetunge, S.P.; Wijetunge, U.S.; Peiris, G.R.V.; Aluthgedara, C.S.; Samarasinghe, A.T.L.K., Design and Implementation of a Bluetooth based General Purpose Controlling Module, *Information and Automation for Sustainability, 2008. 4th International Conference*.
- [10] Taufiq Noor Machmuda , LPG Gas Detector and leak prevention based microcontroller, 2009.