

RFID-Based Automatic Vehicle Parking System Using Microcontroller

Karma Tsheten Dorjee¹, Deepak Rasaily², Bishal Cintury³

¹ Diploma Student in Dept. of Electronics & Communication Engineering, CCCT Polytechnic

² Sr. Lecturer in Dept. of Electronics & Communication Engineering, CCCT Polytechnic

³ Diploma Student in Dept. of Electronics & Communication Engineering, CCCT Polytechnic
Chisopani, P.O. Nandugaon, South Sikkim, India

Abstract — This project is an innovative electronic parking payment system that provides the ultimate solution for drivers, municipalities and private parking lot owners. This enables the drivers to be charged for the exact period of time parked, while simplifying the monitoring and collection of parking fees. This powerful RFID card functions as an in vehicle parking meter, eliminating the need to search for coins when finding a parking place. This project also provides an efficient alternative to coin operated meters and pay and display ticketing systems. Simple and cost effective to implement, this project operates as a standalone system or alongside traditional parking payment systems to eliminate fraud and reduce cash handling.

Every driver owns his vehicle parking card. This card contains the amount for the parking fares. The smart card readers will be fixed everywhere at the car parking centres. If a person wants to park his car in the parking centre, he has to show his parking card before the reader before parking. The reader reads the in time of the car and passes the data to the microcontroller. When the car exits out from the parking centre, the driver once again has to show his card so that the reader records the out time now. Checking the in and out times, the controller calculates the parking fare and automatically deducts this amount from the driver parking card. If the balance is low in the card, a buzzer alert will be indicated and the user has to recharge the card for the parking fares. The amount of balance deducted will be visualized on LCD display.

Keywords:- Motor Driver, Microcontroller AT89S52, LCD, RFID.

I. INTRODUCTION

8051 is the name of a big family of microcontrollers. The device which we used in our project was the 'AT89S52' which is a typical 8051 microcontroller manufactured by Atmel. The 89S52 has 4 different ports, each one having 8 Input/output lines providing a total of 32 I/O lines [1]. Those ports can be used to output DATA and orders do other devices, or to read the state of a sensor, or a switch. Most of the ports of the 89S52 have 'dual function' meaning that they can be used for two different functions.

The first one is to perform input/output operations and the second one is used to implement special features of the microcontroller like counting external pulses, interrupting the execution of the program according to external events, performing serial data transfer or connecting the chip to a computer to update the software. Each port has 8 pins, and will be treated from the software point of view as an 8-bit variable called 'register'[2], each bit being connected to a different Input/output pin. There are two different memory types: RAM and EEPROM. Shortly, RAM is used to store variable during program execution, while the EEPROM memory is used to store the program itself, that's why it is often referred to as the 'program memory'. It is clear that the CPU (Central Processing Unit) is the heart of the micro controllers [3]. It is the CPU that will Read the program from the FLASH memory and execute it by interacting with the different peripherals.

II. MY PROJECT

Radio-frequency identification (RFID) is an automatic identification method wherein the data stored on RFID tags or transponder is remotely retrieved [1]. The RFID tag is a device that can be attached to or incorporated into a product, animal or person for identification and tracking using radio waves. Some tags can be read from several metres away, beyond the line of sight of the reader. RFID technology is used in vehicle parking systems of malls and buildings [3]. The system normally consists of a vehicle counter, sensors, display board, gate controller, RFID tags and RFID reader. Presented here is an automatic vehicle parking system using AT89S52 microcontroller. The device which we used in our project was the 'AT89S52' which is a typical 8051 microcontroller manufactured by Atmel.

III. BLOCK DIAGRAM

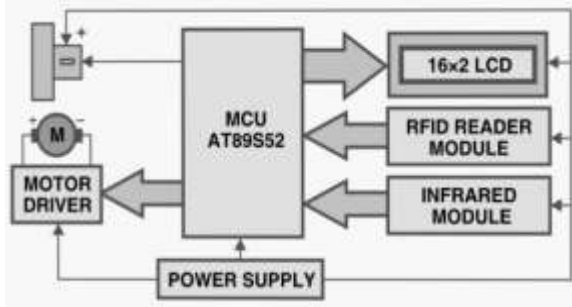

Fig.1 shows the block diagram.

MICROCONTROLLER

The device which we used in our project was the 'AT89S52' which is a typical 8051 microcontroller manufactured by Atmel. The 89S52 has 4 different ports, each one having 8 Input/output lines providing a total of 32 I/O lines [4][5]. Those ports can be used to output DATA and orders do other devices, or to read the state of a sensor, or a switch. Most of the ports of the 89S52 have 'dual function' meaning that they can be used for two different functions.

2. LCD: We are going to use 16x2 alphanumeric Liquid Crystal Display (LCD) which means it can display Alphabets along with numbers on 2 lines each are containing 16 characters.

L293D (MOTOR DRIVING IC):-

The Device is a monolithic integrated high voltage, high current four channel driver designed to accept standard DTL or TTL logic levels and drive inductive loads (such as relays solenoids, DC and stepping motors) and switching power transistors. To simplify use as two bridges each pair of channels is equipped with an enable input. A separate supply input is provided for the logic, allowing operation at a lower voltage and internal clamp diodes are included. This device is suitable for use in switching applications at frequencies up to 5 kHz. The L293D is assembled in a 16 lead plastic package which has 4 centre pins connected together and used for heat sinking The L293DD is assembled in a 20 lead surface mount which has 8 centre pins connected together and used for heat sinking.

Radio-Frequency Identification (RFID):

Radio-Frequency Identification uses electromagnetic fields to automatically identify and track tags attached to objects. The tags contain electronically stored information. Passive tags collect energy from a nearby RFID reader's interrogating radio waves. Active tags have a local power source such as a battery and may operate at hundreds of meters from the RFID reader [6]. Unlike a barcode, the tag need not be within the line of sight of the reader, so it may be embedded in the tracked object. RFID is one method for Automatic Identification and Data Capture (AIDC)

IV. CIRCUIT AND PCB LAYOUT

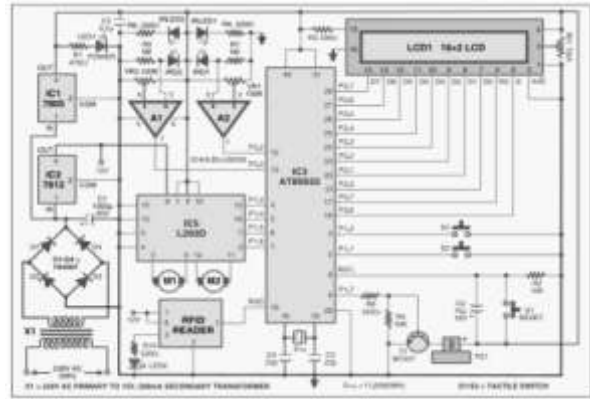

Fig 2 shows circuit diagram.

Fig. 2 shows the circuit of the RFID- based automatic vehicle parking system. The circuit can be divided into different sections: Power supply. Connector CON1 diodes D1 through D4, capacitor C1, and voltage regulator ICs 7805 (IC1) and 7812 (IC2) form the power supply section of the automatic vehicle parking system. CON1 is a three-pin connector that provides 15V AC or DC power supply to the circuit. In case of 15V AC, diodes D1 through D4 form a bridge rectifier to rectify the AC supply. Capacitor C1 filters out the ripples from the rectified output. ICs 7805 and 7812 provide regulated +5V and +12V, respectively[6], to the circuit. +5V is used to operate the microcontroller, LCD, RFID and IR sensor circuit and +12V operates the motor. AT89S52 microcontroller. AT89S52 is a low-power, high performance CMOS 8-bit microcontroller with 8kB Flash memory. It is compatible with the industry-standard 80C51 instruction set and pin-out. The on-chip Flash allows the program memory to be reprogrammed in-system or by a conventional non-volatile memory programmer. Other features include 256 bytes of RAM, 32 input/output lines, watchdog timer, two data pointers, three 16-bit timers/counters, a six-vector two-level interrupt architecture, a full-duplex serial port, on-chip oscillator and clock circuitry. Connectors CON2 through CON4. CON2 and CON3 are two-pin connectors that connect the 12V DC motors to the circuit for controlling the entry and exit gate booms. CON4 is a ten-pin dual-in-line female connector that connects the RFID reader module to the circuit. L293D motor driver. H-bridge DC motor driver L293D (IC5) operates the DC motors to open the door or barrier for entry into and exit from the parking lot. Two high-current motor drivers can be used in place of L293D and 12V DC motors to control the entry and exit gates, respectively. LM358 op-amp. Dual-operational amplifier LM358 (IC4) is used as a voltage comparator to compare the output of the IR sensors with a fixed threshold voltage in order to know whether the IR beam is interrupted or not. IR transmitter and receiver. Two IR transmitter-receiver pairs are used. The IR LEDs are connected in

forward-biased condition to the +5V power supply through 220-ohm resistors. These emit IR light, which is interrupted when an object comes into its way to the IR receiver[7]. The IR receiving photodiodes are connected in reverse-biased condition to +5V power supply through 1-mega-ohm resistors. When the IR light falls on the photodiodes, their resistance changes and so does their output. This output is compared with a fixed voltage to give a digital output to the microcontroller in order to judge the entry and exit of the vehicles. LCD display. LCD1 is a two-line, 16-character, alphanumeric liquid crystal display. Data lines D0 through D7 of the LCD are connected to port 2 of AT89S52 (IC3). Reset (RS) and enable (E) control lines are connected to port pins P3.6 and P3.7, respectively. Control lines control data flow from the microcontroller to LCD1. When power is switched on, LED1 glows to indicate the presence of power in the circuit and LED2 glows to indicate the presence of RFID reader. Simultaneously, the 'Automatic RFID Car Parking' message is displayed on LCD1 along with a short beep from piezobuzzer PZ1. Transistor BC547 drives the buzzer. Pin details of 7805, 7812 and BC547 are shown in Fig. 6. When a car crosses the IR LED1- D1 pair installed at the entry gate, the gate boomer does not open until an RFID tag is placed near the RFID reader. After the tag is placed near the reader, the gate boomer opens for three seconds and closes automatically. If the initial recharge amount was Rs 900, the LCD display shows 'Vehicle1 Amount' in the first line and 'Deducted 100' in the second line, followed by 'Balance Amount' in the first line and '800' in the second line. It is then followed by display of 'Number of Cars' in the first line and '001' in the second line. If the parking lot is full, the message "Parking is Full, Sorry for Inconvenience" is displayed on LCD1. When a car leaves the parking area and crosses the IR beam between IR LED2 and D2 at the exit gate, the vehicle count decreases by one. The LCD shows the number of cars in the parking lot along with "Thanks for Visiting" message.

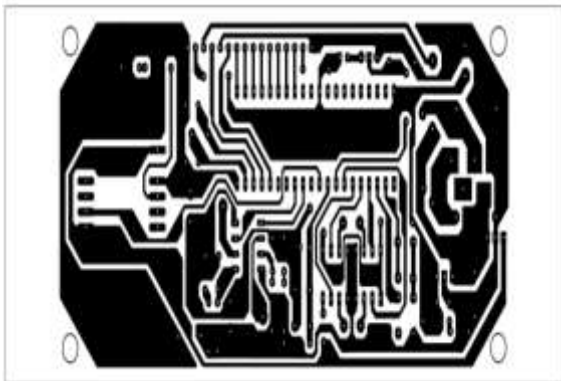

Fig. 3: An actual-size PCB layout of RFID-Based Automatic Vehicle Parking System Using Microcontroller

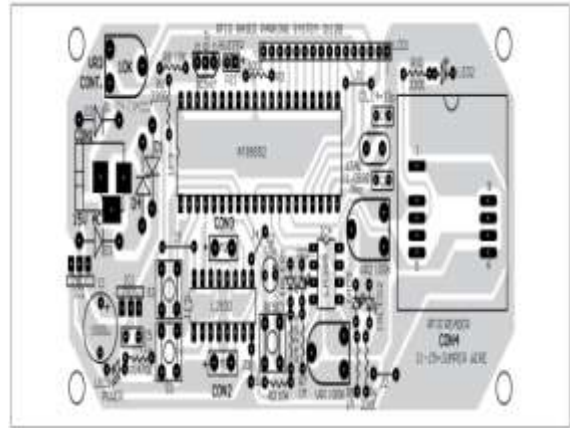

Fig. 4: component layout of RFID-Based Automatic Vehicle Parking System Using Microcontroller.

Working

Fig. 1 shows the block diagram of the RFID-based automatic vehicle parking system. To get started with RFID-based automatic vehicle parking system, the vehicle owner has to first register the vehicle with the parking owner and get the RFID tag. When the car has to be parked, the RFID tag is placed near the RFID reader, which is installed near the entry gate of the parking lot. As soon as the RFID tag is read by the reader, the system automatically deducts the specified amount from the RFID tag and the entry gate boomer opens to allow the car inside the parking area[9][8]. At the same time, the parking counters increments by one. Similarly, the door is opened at the exit gate and the parking counter decremented. The system also offers the facility to recharge the amount for each RFID tag. No manual processing is involved. In addition, the system provides security.

Construction

An actual-size, single-side PCB layout for the RFID based automatic vehicle parking system is shown in Fig. 3 and its component layout in Fig. 4. Burn the hex code into the AT89S52 micro- controller using a suitable programmer and then mount the microcontroller on the PCB. Install IR LED1-D1 pair at the entry gate such that these face each other. Similarly, install IR LED2-D2 pair at the exit gate. For testing, switch on the circuit, interrupt the infrared beam between IR LED1 and IR D1 with your hand or some other opaque object and then remove it, and place the tag near the reader. The LCD should show the message as described earlier in 'How this vehicle parking system works' section. An amount of Rs 100 should be deducted for every interruption of the IR beam. The card can be recharged by pressing the pushbutton switches (S2 and S3) provided in the circuit. Pressing switch S2 recharges the card with Rs 900 and pressing switch S3 recharges it with Rs 500. Similarly, interrupt the IR beam at the exit gate[10]. LCD1 should show the number of cars in the parking lot along.

V. RESULT

RFID based Prepaid Car Parking System has application in many areas like Industries, Companies, Offices, Shopping malls. We have provided a DC motor and Relay to show the demo of valid security access. And a buzzer is provided which is turned on when an invalid RFID card is shown to the reader. Keypad is provided with this project. Keypad is used in recharge mode to add the balance in RFID card. Keypad is also used to select manual or normal mode. Infrared sensor is used to detect car.

VI. CONCLUSION

This paper discusses the importance of using a RFID based Parking Management System. This system facilitates faster user authentication and hence results in reduced waiting time and increases the efficiency of the parking space

VII. REFERENCE

- [1] R.Ranjini1, D.Manivannan2, A Comparative Review on Car Parking Technologies presented at International Journal of Engineering and Technology (IJETT).
- [2] R.C. Luo, T.M. Chen, and C.C. Yih, "Intelligent autonomous mobile robot control through the Internet,"IEEE International Symposium ISIE 2000, vol. 1, pp. 6-11, December 2000.
- [3] G. Arangurenss, L. Nozal, A. Blazquez, and J. Arias, "Remote control of sensors and actuators by GSM", IEEE 2002 28th Annual Conference of the Industrial Electronics Society IECON 02, vol. , 5-8 Nov. 2002,pp.2306 – 2310.
- [4] L. Schenker, "Pushbutton Calling with a Two- Group Voice-Frequency Code", The Bell System Technical Journal, 39(1), 1960, 235–255, ISSN 0005-8580.
- [5] P. Pradeep, M. Prabhakaran, B. Prakash, P. Arun Kumar, and G. Gopu, "Advanced Design for Robot in Mars Exploration," presented at 2010 International Conference on Industrial Engineering and Operations Management Dhaka, Bangladesh, January 9 – 10, 2010.
- [6] T. Nguyen and L. G. Bushnell, "Feasibility Study of DTMF Communications for Robots," Dept of EE, University of Washington Seattle WA, 98195-2500, April 6, 2004
- [7] Technology Intelligent Home: SMS Based Home Security System with Immediate Feedback International Journal of Advance Research in Science and Engineering <http://www.ijarse.com> IJARSE, Vol. No.2, Issue No.5, May, 2013 ISSN-2319-8354(E).
- [8] Cannan, J. and Hu, H., "Human-Machine Interaction (HMI): A Survey".[Online]. Available: <http://www.dces.essex.ac.uk/staff/hhu/Papers/CES-508%20HMI-Survey.pdf>
- [10] Das, S., Toya, L., Green, Perez, B., and Murphy, M. M., "Detecting User Activities using the Accelerometer on the Smartphone", Team for Research in Ubiquitous Secure Technology REU Research Program, July 2010.

Authors:

[1]



Karma Tsheten Dorjee is a student doing his diploma in Electronics and Communication in Centre for Computers and Communications Technology, Chisopani, south Sikkim, India. His area of interest is in Microprocessor, Advanced Communication, Satellite and Cellular Communication, Microcontroller, PLC and Digital Electronics.

[2]



Deepak Rasaily is presently associated with the Department of Electronics and Communication Engineering at Centre for Computer and Communication Technology (CCCT-Govt.Polytechnic) Chisopani, South Sikkim, India as a Senior Lecturer since 2003 to till date. He is ME-Scholar at National Institute of Technical Teachers' Training & Research, Chandigarh, India. He Worked as Project Scientist in the Department of Science and Technology, Govt.of Sikkim prior to Lecturer in CCCT. His areas of interest are PLC and Robotics, Microprocessors and Microcontroller and Digital Signal Processing.

[3]



Bishal Cintury is a student doing his diploma in Electronics and Communication in Centre of Computers and Communications Technology, Chisopani, South Sikkim, India. His area of interest is in Microcontroller, Antenna and Fibre Optics, Satellite and Cellular communications and Analog Electronics.