

# Password Protected Lock System Designed using Microcontroller

Aarfin Ashraf<sup>1</sup>, Deepak Rasaily<sup>2</sup>, Anita Dahal<sup>3</sup>

<sup>1</sup> Diploma Student in Dept. of Electronics & Communication Engineering, CCCT Polytechnic

<sup>2</sup> Sr. Lecturer in Dept. of Electronics & Communication Engineering, CCCT Polytechnic

<sup>3</sup> Diploma Student in Dept. of Electronics & Communication Engineering, CCCT Polytechnic  
Chisopani, P.O. Nandugaon, South Sikkim, India

**Abstract** — The purpose of this project is to provide security at (house, ATM, office etc.) in this system the user will have to register a unique password. The information will be stored in data base. Whenever the right password will be received, the controller will accordingly give instruction to dc motor. Dc motor will perform the action on door unlocking. We want to utilize the electronic technology to build an integrated and fully customized home security system at a reasonable cost.

**Keywords**— Motor, Microcontroller, LCD, Keypad, Buzzer.

## I. INTRODUCTION

The AT89C51 is a low-power, high-performance CMOS 8-bit microcomputer with 4Kbytes of Flash programmable and erasable read only memory (PEROM). The device is manufactured using Atmel's high-density non-volatile memory technology and is compatible with the industry-standard MCS-51 instruction set and pin out. The on-chip Flash allows the program memory to be reprogrammed in-system or by a conventional non-volatile memory programmer. By combining a versatile 8-bit CPU with Flash on a monolithic chip, the Atmel AT89C51 is a powerful microcomputer which provides a highly-flexible and cost-effective solution to many embedded control applications [1].

The AT89C51 provides the following standard features: 4Kbytes of Flash, 128 bytes of RAM, 32 I/O lines, two 16-bit timer/counters, five vector two-level interrupt architecture, a full duplex serial port, and on-chip oscillator and clock circuitry [12]. In addition, the AT89C51 is designed with static logic for operation down to zero frequency and supports two software selectable power saving modes. The Idle Mode stops the CPU while allowing the RAM, timer/counters, serial port and interrupt system to continue functioning. The Power-down Mode saves the RAM contents but freezes the oscillator disabling all other chip functions until the next hardware reset.

Some microcontrollers may use four-bit *words* and operate at *clock rate* frequencies as low as 4 kHz, for low power consumption (single-digit mill watts or microwatts). They will generally have the ability to retain functionality while waiting for an event such

as a button press or other interrupt; power consumption while sleeping (CPU clock and most peripherals off) may be just Nano watts, making many of them well suited for long lasting battery applications. Other microcontrollers may serve performance-critical roles, where they may need to act more like a digital signal processor (DSP), with higher clock speeds and power consumption.

## II. MY PROJECT

This system demonstrates a circuit named Password Protected Lock System Designed using Microcontroller where in once the correct code or password is entered, the door is opened and the concerned person is allowed access to the secured area. After some time, the door would close. Again if another person arrives and fails to enter the correct password, the door would remain closed, denying access to the person.

Many times we forgot to carry the key of our home. Or sometimes we come out of our home and door latch closes by mistake. In these cases it is really difficult to get inside the house. This project is designed to solve this purpose. Main concept behind this project is of a door-latch opening using a password entered through keypad. As well as turning on the Buzzer when password is entered wrong for multiple times. User can change this password anytime he/she wish using a keypad [2].

The main component in the circuit is 8051 microcontroller. Here, 4×3 keypad is used to enter the password. The entered password is compared with the predefined password. If it is correct password, the system opens the door by rotating door motor and displays the status of door on LCD. If the password is wrong then door remains closed and displays “password is wrong” on LCD.

### III. BLOCK DIAGRAM

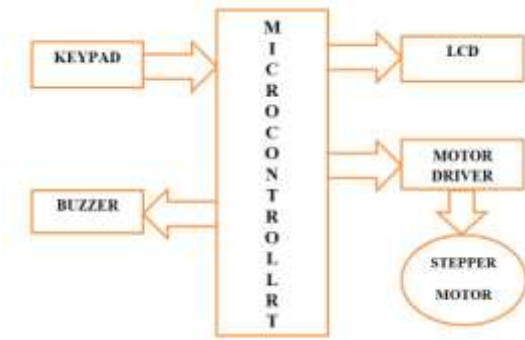

Fig.1 shows the block diagram.

The microcontroller based door locker is an access control system that allows only authorized person to access a restricted area [3]. The system is fully controlled by the 8 bit microcontroller 8051 which has a 2Kbytes of ROM for the program memory. The password is stored in the EPROM so that we can change it at any time.

The system has a keypad by which the password can be entered through it. When the entered password equals with the password stored in the memory then the relay gets on and so that the door is opened. If we entered a wrong password for more than three times then the alarm is switched on.

There are two relays one to open the door and other to close the door. There is an button which should be placed inside the door so that the person inside can open/close the door

**A. Microcontroller:** This is the CPU (central processing unit) of our project. We are going to use a Microcontroller of 8051 family. The various functions of microcontroller are like:

- I. Reading the digital input from Keypad.
- II. Sending this data to LCD so that the person operating this project should read the password.
- III. Sensing the password using keypad and to check whether it is a correct password or a wrong. Password and rotate the stepper motor if the password entered is a correct password.
- IV. Sending the data to the computer using serial port. This data consist of the status of entered Password (Correct/wrong).

**B. LCD:** We are going to use 16x2 alphanumeric Liquid Crystal Display (LCD) which means it can display Alphabets along with numbers on 2 lines each are containing 16 characters.



**C. Buzzer:** We are going to use a buzzer to indicate the wrong password to open the door.

**D. Keypad:** User will enter the password using the keypad. Various keys of keypad are as following,  
I. 0 to 9 II. Enter III. Escape

### E. Motor driver IC (L293D):

The Actuator's are those devices which actually gives the movement or to do a task like motor's. In the real world there are various types of motors available which works on different voltages. So we need motor driver for running them through the controller. To get interface between motor and microcontroller [4]. We use L293D motor driver IC in our circuit. The Device is a monolithic integrated high volt- age, high current four channel driver designed to accept standard DTL or TTL logic levels and drive inductive loads (such as relays solenoids, DC and stepping motors) and switching power transistors. To simplify use as two bridges each pair of channels is equipped with an enable input. A separate supply input is provided for the logic, allowing operation at a lower voltage and internal clamp di- odes are included. This device is suitable for use in switching applications at frequencies up to 5 kHz[9]. The L293D is assembled in a 16 lead plastic package which has 4 centre pins connected together and used for heat sinking The L293DD is assembled in a 20 lead surface mount which has 8 centre pins connected together and used for heat sinking.

### IV. CIRCUIT AND PCB LAYOUT

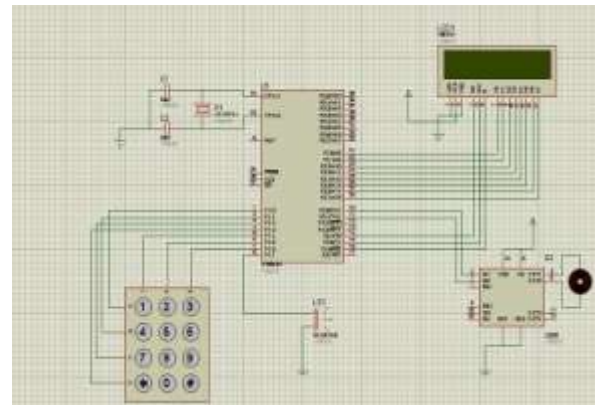

Fig.2 shows Circuit diagram.

Following are the main components required to build this circuit –

- A. Hardware Requirements:**
- at89c51 controller
  - 8051 programming board
  - Programming cable
  - DC battery or 12V,1A adaptor
  - 4x3 matrix keypad
  - 16x2 LCD
  - 5V Relay
  - DC motor
  - BC 547 Transistor
  - 10k, 330 Ω resistor (1/4 watt)
  - 10uF electrolytic capacitor
  - 33pF capacitors – 2
  - 12MHz Crystal
  - Pot 10k (1/4 watt) – 1
  - connecting wires

### B. Software Requirements:

Kiel compiler  
Flash magic  
Proteus

### C. Principle behind the Circuit:

The main component in the circuit is 8051 microcontroller. Here, 4×3 keypad is used to enter the password. The entered password is compared with the predefined password. If it is correct password, the system opens the door by rotating door motor and displays the status of door on LCD. If the password is wrong then door remains closed and displays “pwd is wrong” on LCD[5][6].

Its design and working are very interesting and easy to implement. If you are interested to get detailed information about its design, working and applications, read the post Electronic Code Lock System using 8051 Microcontroller.

Traditional lock systems using mechanical lock and key mechanism are being replaced by new advanced techniques of locking system [10]. These techniques are an integration of mechanical and electronic devices and highly intelligent. One of the prominent features of these innovative lock systems is their simplicity and high efficiency.

### D. Circuit Description

The total functioning of the “CODE LOCK SYSTEM” is based on the software program which is burn inside the microcontroller IC 8051.

The AT89C51 IC is heart of the given circuitry because this IC is programmable 40pin dip IC in which we burn the program in ROM[8]. This IC has a 32 I/O lines through which we take the output pin no 9 is used for reset the microcontroller and make it in a initial condition pin no 31 is enable pin, It required low pulse for activating the microcontroller depends on the crystal connected to the xtal1 & xtal2. Pin no 18&19 is used for providing the vcc of +5v pin 20 is grounded [7].

The operating frequency of the controller is set by the external oscillator of crystal oscillator of crystal having frequency of 12MHZ. Capacitor having 33pF in parallel connection with ground is for the proper undammed frequency. Reset for the controller is normally ground and 10uf 10v electrolytic capacitor is also connected on reset for the slowly on and off to the controller during the supply is turning on and off. The keypad used to give input signal is been interfaced with the microcontroller are port0 (p0.1- p0.7), The controller fetches the hex code according to the instruction.

The LCD is used for display device it is a 16 slots device usually used to show output status from the microcontroller [11]. The output signal which be fetched by relay status followed by on/off status of electronic lock.

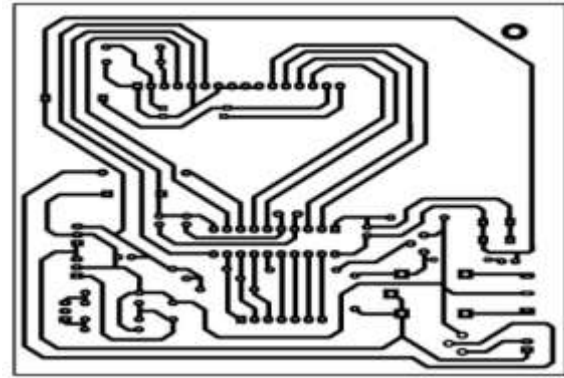

Fig 3 show the pcb layout

### V. RESULT AND SIMULATION

- When it is entered a 4 digit password by the user it will display on LCD as “\*\*\*\*”. Therefore anyone else can't see what the user enters.
- If it is the correct password, LCD displaying a message “Well come” and the door will be opened. after 1minuts time door is locked automatically.
- If it is entered password incorrectly LCD displaying “password error”
- If it is a wrong password user received another 3attempts to enter the correct one. If he couldn't enter password correctly by these attempts he have to wait 3 minutes time more to re logged in to the system.
- After opening the door if user wants to change his password, after pressing “0” key and giving user id user can change his password.
- If user wants to add more people to the system after opening the door pressing “#” key, user can add more users. System will give user id to each password.

Simulation of project is performed on PROTEUS and the code was written Kiel software. Code for the microcontroller to run DC motors using the H-Bridge IC (L293D) is written. In the simulation the relevant data to the Microcontroller is send through keypad. The Microcontroller processed the data and sent the information to the Actuator IC (L293D). The Actuator IC upon receiving information showed response by driving the DC motors.

### VI. CONCLUSION

The work was done successfully. It is evidence that the use of keypad with the right circuitry can be used to operate a security system. These systems have the ability to accesses a secure place (house, ATM, industries, office etc.). A password based recognition system can easily perform variation. In variation the system compare an input password to the enrolled password of a specific user to determine, if they are form the same password. Now the security of our home, office etc.

### Future Scope

- We can send this data to a remote location using mobile or internet.
- We can add fingerprint sensor so entry will be allowed for the authorized person using their fingerprints.
- We can add fire, wind and LPG sensors so that, the doors will automatically open.

### VII. REFERENCE

- [1] Technology Intelligent Home: SMS Based Home Security System with Immediate Feedback International Journal Of Advance Research In Science And Engineering <http://www.ijarse.com> IJARSE, Vol. No.2, Issue No.5, May, 2013 ISSN-2319-8354(E).
- [2] Liu, T., Guo, H., and Wang, Y., “A new approach for color-based object recognition with fusion of color models”, Congress on Image and Signal Processing Conference, Sanya-China, vol. 3, pp. 456-460, May 2008.
- [3] Wang, B., and Yuan, T., “Traffic Police Gesture Recognition using Accelerometer”, IEEE SENSORS Conference, Lecce-Italy, pp. 1080-1083, Oct. 2008.
- [4] Lalanne, T., and Lempereur, C., “Color recognition with a camera: a supervised algorithm for classification”, IEEE Southwest Symposium on Image Analysis and Interpretation, Tucson-Arizona, pp. 198-204, April 1998.
- [5] Signals, Systems and Computers, 2004 Conference Record of the Thirty-Eighth Asilomar Conference on Publication 7-Nov-2004 Volume: 1, on page(s): 577-581 Vol.1.
- [6] International Journal of Advanced Research in Computer Science and Software Engineering, Volume 2, Issue 10, October 2012.
- [7] International Journals of Biometric and Bioinformatics, Volume (3): Issue (1).
- [8] Mukesh Kumar Thakur, Ravi Shankar Kumar, Mohit Kumar, Raju Kumar “Wireless Fingerprint Based Security System using Zigbee”, International Journal of Inventive Engineering and Sciences (IJIES) ISSN: 2319-9598, Volume-1, Issue-5, April 2013.
- [9] Mary Lourde R and Dushyant Khosla, “Fingerprint Identification in Biometric Security Systems”, International Journal of Computer and Electrical Engineering, Vol. 2, No. 5, October, 2010.
- [10] Song, M., Kim, B., Ryu, Y., Kim, Y., and Kim, S., “A design of real time control robot system using android Smartphone” The 7th International Conference on Ubiquitous Robots and Ambient Intelligence (URAD), BusanKorea, Nov. 2010.
- [11] Shilpa, V., Pradeep, H. S., and Kurian, M. Z., “The Symbian Robot,” International Journal of Computer Science and Informatics (IJCSI), Vol-1, Issue-3.
- [12] M. Klingmann, “Accelerometer-Based Gesture Recognition with the iPhone”, Goldsmiths University, MSc in Cognitive Computing, London, September 2009.

### Authors:

[1]



**Aarfin Ashraf** is a final year Diploma student, Dept. Of Electronics and Communication Engineering from Centre for Computer and Communication Technology,

Chisopani, South Sikkim. His main areas of interest are Antenna Design, Radar Signal Processing and Microwave Theory and Techniques.

[2]



**Deepak Rasaily** is presently associated with the Department of Electronics and Communication Engineering at Centre for Computer and Communication Technology (CCCT-Govt.Polytechnic) Chisopani, South Sikkim, India as a Senior Lecturer since 2003 to till date. He is ME-Scholar at National Institute of Technical Teachers' Training & Research, Chandigarh, India. He Worked as Project Scientist in the Department of Science and Technology, Govt.of Sikkim prior to Lecturer in CCCT. His areas of interest are PLC and Robotics, Microprocessors and Microcontroller and Digital Signal Processing.

[3]



**Anita Dahal** is a final year Diploma student, Dept. Of Electronics and Communication Engineering from Centre for Computer and Communication Technology, Chisopani, South Sikkim. Her main areas of interest are Analog and Digital Circuits, Embedded Systems and Wireless Communication & Networking.