

# Voice Based Electronic Travelling Aid Using Flex Sensor for Blind People

Nagamani K. <sup>#1</sup>, Aditya Gaurav <sup>\*2</sup>, Yatindra Mishra <sup>\*3</sup>, Satwik Kashyap <sup>\*4</sup>

<sup>#</sup> Assistant Professor, <sup>\*B.E. Student</sup>  
Telecommunication Engineering, R.V.C.E,  
Bangalore, Karnataka, India.

**Abstract**— In this paper, a detailed study about the design of a wearable assistive smart and intelligent system using flex sensor is presented, which could be the replacement of the blind stick, making the overall system smart and unique in its capabilities helping the blind travel with more convenient means of life. The system is used to assist blind by providing him information about the approaching obstacle using an ultrasonic sensor which works on the property of sonar and a voice system which informs the blind with a specific instruction continuously while the blind can get the real time current location through speaker/headphone using a global positioning system with the movement of flex sensor placed on his fingers only. The ultrasonic sensor and the GPS receiver are interfaced with a micro-controller to carry out the functions making it the central hub of the system.

**Keywords**— FLEX SENSOR, GPS, ADC, APR9600 and MICROCONTROLLER 8051.

## I. INTRODUCTION

The count of visually impaired people rises every year. Currently the number is estimated to be around 285 million. Of this number, 39 million are blind while 246 are said to be suffering from low vision problems. Everyday life of visually impaired people is very difficult especially when it comes to move around in traffic resulting from ever growing population and vehicles. In everyday life they undergo problem of navigation to reach from one place to another safely and timely. In past, number of devices are made to assist them in travelling so that they can reach their destination timely and safely.

Most of those devices operate on the conventional blind stick. But in order to make them not even feel the burden of carrying long and heavy stick, a design of a wearable assistive smart and intelligent system using flex sensor is presented, which could be the replacement of the blind stick, making the overall system smart and unique in its capabilities helping the blind travel with more convenient means of life.

Other devices used earlier for the navigation purposes were walking cane, guide dog, and sighted guide. All these devices work well as long as blind people are within familiar operating environment and they also affect the independence of blind people.

The exact position, orientation and coordinates of any place on the globe will be known to blind using GPS receiver

module, thus they can discover unknown places to them. This GPS technology is very reliable to use as satellite access or link is always present throughout the globe anytime and every time. This technology of GPS can only give idea of the current location of the place but obstacles /hindrance present in the path can be found out using ultrasonic sensor which helps improve the resolution and proximity detection to avoid collision.

Ultrasonic sensor uses ultrasound which is noise resistant. It can be used to find out range of the obstacle present in the path away from the blind people. Being cost effective, least affected by target materials, surfaces and colour and small and compact compared to conventional sensors, it is very popular and useful.

Flex sensors are placed on the glove of blind people, so that he can get real time assistance by bending his fingers in different modes which results in stable, reliable, compact and efficient system as compared to conventional navigation systems of blind walking cane stick.

These different units are discussed to implement the design of a voice based electronic travelling aid using flex sensor.

## II. DESIGN AND IMPLEMENTATION

The blind alert system using flex sensors is a wearable, smart, portable and efficient device for the blind people, it consists of GPS, ultrasonic sensors and flex sensor interfaced with the microcontroller which is the responsible for performing all operations. The hardware implementation of the system is shown in figure 1.

### A. Flex Sensor

Flex sensors are the devices which work on the principle of the change of resistance. The resistance of the flex sensor changes with the change in angle of the bending. The output voltage provided by the flex sensor depends on the change of resistance within the flex sensors. The GPS is controlled by the flex sensor which on bending provides the current location of the blind.

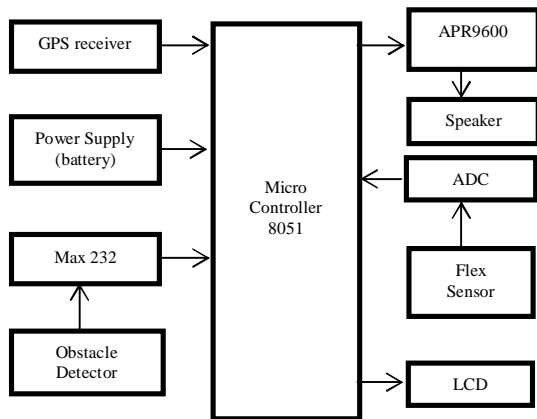

**Figure 1.** Hardware implementation

*B. Analog To Digital Converter (ADC)*

Analog to digital convertor is used to convert the analog values of the flex sensor voltage output and convert it to digital values based on sampling and quantization process.

*C. Global Positioning System (GPS)*

GPS is used for the detection of the present location of the blind. This is achieved by interfacing the GPS with microcontroller. The microcontroller after the reception of data from GPS provides the current location of the person through speaker when flex sensor is twisted.

*D. Max 232 And Obstacle Detector*

Ultrasonic sensors are used to detect the approaching obstacle. This is achieved by interfacing the ultrasonic sensor with max 232 which provides TTL output. Microcontroller is compatible with the TTL logic and output of the MAX 232 is fed as the input of the microcontroller. The ultrasonic sensors works on the property of sending and receiving the ultrasonic waves. The ultrasonic waves are sent by the sensor and then the waves are reflected by the obstacle and upon receiving the waves the distance is calculated using the total time and the velocity of the waves. The ultrasonic sensor works at 42 kHz frequency.

*E. APR9600 And Speaker*

APR9600 device offers true single-chip voice recording, non-volatile storage and playback capability for 40 to 60 seconds. The voice synthesizer is used to generate speech signal output of current location and obstacle, if present, which is in the form of announcement through speaker.

*F. Microcontroller 8051*

The microcontroller 8051 is the central hub which performs all the operations and all components are interfaced with it for its functioning. The software used is Keil-c compiler which is

used to write the programs in embedded c for the microcontroller and the functioning of the speech unit.

*G. LCD*

LCD is used as a reference to check the working of the proposed system. LCD shows the response for obstacle detection and the reading of latitude and longitude of the place where the person is standing or walking.

**III. RESULTS AND INFERENCE**

The wearable assistive smart and intelligent system based on flex sensor is developed to assist visually impaired people. The system is able to handle navigation problems, for e.g. going to unknown places and to detect obstacle present in the pathway. The code is programmed and fed into the microcontroller to make the proposed system responds to the detection of obstacle and location of current place .The proposed system is composed of Global Positioning System and obstacle detection system .The results confirmed the usefulness by providing real time assistance and support of the system in reducing the access time required by the blind people to reach different locations. The proposed system is designed and configured for practical use. The system is efficient and unique in its capability.

**IV. STEP BY STEP RESULTS**

Step by step results are obtained and are shown in the figures below.

*A. Hardware Initializing*

When the hardware kit is supplied power through battery then LCD shows the output “waiting for request” during its initial stages which signifies that the device is initialized as shown in figure 2.



**Figure 2.** LCD Initialisation

*B. LCD Showing The Response For Obstacle Detection*

The figure 3 displays the output given by the ultrasonic sensor. The ultrasonic sensor produces the output on the basis of the range. When the obstacle is within a distance of 50 inches from the blind person, the LCD gives the output “object is nearer” with its range in inches displayed in the first row of LCD as shown in figure 3.



Figure 3. Ultrasonic Detector Output

C. LCD Showing The Latitude And Longitude For Different Locations

The LCD shows the reading of latitude and longitude of the place where the person is standing or walking as shown in figure 4.



Figure 4. Latitude And Longitude Of Telecommunication Department, R.V.C.E.

D. Output From Speaker

Speaker gives the output of voices recorded on APR9600 speech unit for corresponding latitude and longitude of the place.

V. CONCLUSION

The proposed project resulted in designing a system which is useful for visually impaired people to make them independent and also to lead their life with lesser support from others as shown in figure 5. The wearable assistive smart system uses flex sensors, GPS receiver, ultrasonic sensor and a voice circuit which is interfaced to the microcontroller. The blind alert system is portable, effective and efficient device and helps the blind with more convenient means of life. The system designed consists of a microcontroller programmed in such a way that depending on the satellite information of location the predefined location name will be announced and using the ultrasonic sensor the approaching obstacles will be informed to the visually impaired which makes the overall system smart and unique in its capabilities helping the blind to travel around.

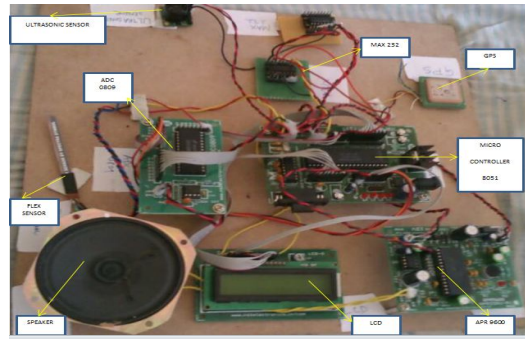

Figure 5. Proposed System using flex sensor

REFERENCES

- [1] Ando, B., "An Environmental Sensor Providing Home Light Classification to Blind People", Instrumentation and Measurement Technology Conference, 2005. IMTC 2005. Proceedings of the IEEE, ISBN: 0-7803-8879-8, Mon Mar 13 00:00:00 EST 2006.
- [2] Bouhamed S. A., Eleuch J. F., Kallel I. K. and Masmoudi D. S., "New electronic cane for visually impaired people for obstacle detection and recognition", 2012 IEEE International Conference on Vehicular Electronics and Safety (ICVS), ISBN: 978-1- 4673-0992-9, Mon Sep 03 00:00:00 EDT 2012.
- [3] Saaïd, M.F., Ismail, I., Noor, M.Z.H., "Radio Frequency Identification Walking Stick (RFIWS): A device for the blind", Signal Processing & Its Applications, 2009. CSPA 2009. 5th International Colloquium on 978-1-4244-4151-8, Fri Jun 05 00:00:00 EDT 2009.
- [4] Rahiman, M.H.F., Rahim, R.A., Rahim, H.A., Ayob, N.M.N. "Novel Adjacent Criterion Method for Improving Ultrasonic Imaging Spatial Resolution", Sensors Journal, IEEE, On page(s): 46 -1747 Volume: 12, Issue: 6, June 2012. B. Smith, "An approach to graphs of linear forms (Unpublished work style)," unpublished.
- [5] Chih-Lyang Hwang, Ying-Jer Chou, Chien-Wu Lan "Comparisons Between Two Visual Navigation Strategies for Kicking to Virtual Target Point of Humanoid Robots", Instrumentation and easurement, IEEE Transactions on, On page(s): 3050 - 3063 Volume: 62, Issue: 11, Nov. 2011. J. Wang, "Fundamentals of erbium-doped fiber amplifiers arrays (Periodical style—Submitted for publication)," *IEEE J. Quantum Electron.*, submitted for publication.
- [6] Mercado, D.A., Flores G., Castillo P., Escareno J., Lozano R. "GPS/INS/optic flow data fusion for position and Velocity estimation", Unmanned Aircraft Systems (ICUAS), 2013 International Conference on, on page(s): 486 – 491.
- [7] Ganz A., Schafer J., Puleo, E., Wilson C., Robertson M. "Quantitative and qualitative evaluation of PERCEPT indoor navigation system for visually impaired users", engineering in Medicine and Biology Society (EMBC), 2012 Annual International Conference of the IEEE, On Page(s): 5815 – 5818.