

FIVE-LEG INVERTER for FIVE-PHASE SUPPLY

K. P. Prasad Rao^{#1}, B. Krishna Veni^{*2}, D. Ravithej^{#3}

[#]Department of Electrical & Electronics Engineering, K L University,

Andhra Pradesh, INDIA

Abstract- Whenever Three-Phase Induction Motor is in running condition, there is a problem with ripple torque & harmonics. This hampers the smooth operation of the machine and it also aggravates the amount of heat generated. The ripple content can be smoothened by supplying the motor with multi phase supply greater than three phase supply. Selection of even number of phases should be avoided, because it degrades the performance of motor as poles coincide with each other. So, Five Phase Supply/Odd Phases may be preferred. This paper proposes a difference between Three-Phase supply and Five-Phase supply. Five-Leg Inverter is a converter converts DC to variable AC (i.e., variable voltage and variable frequency). Output of the five leg inverter is controlled by PWM control technique method. It is highly economical, has more Efficiency and good controllable.

Keywords- Five-Phase Supply (Voltage, Current & Power Relations), Five-Leg VSI, PWM control technique.

I. INTRODUCTION

Multiphase (more than three phase) systems are the focus of research recently due to their inherent advantages compared to their three phase systems. The applicability of multiphase systems is explored in electric power generation [2]-[5], transmission [6],[7] & utilization [8]-[17]. Multi-phase motor drives are concerned, the first proposal was given by Ward and Harrer way back in 1969 [1] and since then the research was slow and steady.

The research on multiphase drive systems has gained momentum at the start of this century due to the availability of cheap ratable semiconductor devices and digital signal processors [10]-[14]. It is to be emphasized here that the multiphase motors are invariably supplied by ac/dc/ac converters. Thus, the focus of the research on the multiphase electric drive is limited to the modeling and controlling of the supply systems [15]-[17]. Little effort is made to develop any static transformation system to change the phase number from three to n- phase [17]. Here the phase sequence is $n > 3$ and odd [16] because six phase transmission lines can be smaller, more complex in tower construction compared to a standard double circuit three phase line [12].

The research on multiphase generators has started recently and only a few references are available. This paper, proposes a phase transformation system which converts an available three-phase supply & DC supply to an output five-phase supply [9]. Multiphase, especially a 6-phase and 12-phase

system is found to produce less ripple with a higher frequency of ripple in an ac-dc rectifier system. Thus, 6- and 12-phase transformers are designed to feed a multipulse rectifier system and the technology has matured. Recently, a 24-phase and 36-phase transformer system had been proposed for supplying a multipulse rectifier system [18]-[20]. The reason for choosing a 6-, 12-, or 24-phase system is that these numbers are multiples of three and designing this type of system is simple and straightforward. However, increasing the number of phases certainly enhances the complexity of the system. None of these designs are available for an odd number of phases, such as 5, 7, 11, etc [22].

II. FIVE-PHASE SUPPLY

A. Three-Phase Supply Voltage, Current & Power relations

Fig. 1 shows three loads connected in the star formation to a three phase four wire supply system. Fig. 2 shows the phasor diagram, the red to neutral voltage V_{RN} is taken as reference and the phase sequence is red, yellow, blue so that the other line to neutral voltages or phase voltages lie as shown.

If $V_{RN} = V_{YN} = V_{BN}$ and they are equally spaced the system of voltage is balanced. Let V_L be the voltage between any pair of lines (the line voltage) and $V_P = V_{RN} = V_{YN} = V_{BN}$ (the phase voltage) Then $V_L = \sqrt{3} V_P$ and $I_L = I_P$. Where I_L is the current in any line and I_P is the current in any load or phase. The power per phase is $P = V_P I_P \cos\phi$ and the total power is the sum of the amount of power in each phase.

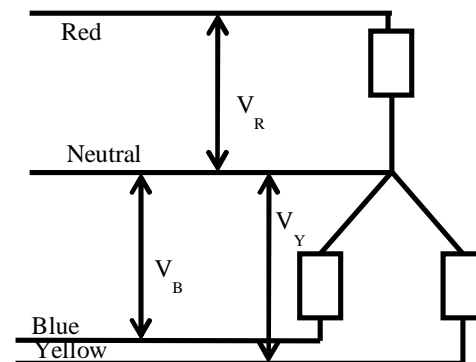

Fig. 1 Star connection (Three-Phase four wire system)

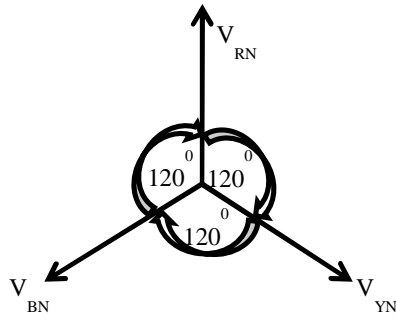

Fig. 2 Phasor representation of three phase voltages

If the currents are equal and the phase angles are the same as in Fig. 3 the load on the system is balanced, the current in the neutral is zero and the total power is, $P = 3V_{ph}I_{ph}\cos\phi$

$$P = \sqrt{3} V_L I_L \cos\phi$$

or

$$P = 1.73 V_L I_L \cos\phi$$

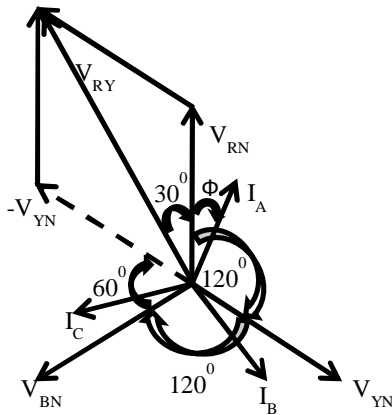

Fig. 3 Phase relationship between phase voltages and currents

B. Five-Phase Voltage, Current & Power relations

Fig. 4 shows the phasor diagram, the red to neutral voltage V_{AN} is taken as reference and the phase sequence is red, yellow, blue, green, purple so that the other line to neutral voltages or phase voltages lie as shown.

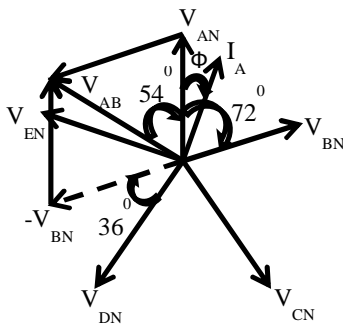

Fig. 4 Phase relationship between voltage and current

If $V_{AN} = V_{BN} = V_{CN} = V_{DN} = V_{EN}$ and they are equally spaced (i.e., 72° each phase) the system of voltage is balanced. Let V_L be the voltage between any pair of lines (the line voltage) and $V_{ph} = V_{AN} = V_{BN} = V_{CN} = V_{DN} = V_{EN}$ (the phase voltage) Then $V_L = \sqrt{1.38} V_{ph}$ or $V_L = 1.175V_{ph}$ and $I_L = I_p$. Where I_L is the current in any line and I_p is the current in any phase. The power per phase is $P = V_p I_p \cos\phi$ and the total power is the sum of the amount of power in each phase.

$$P = 5 V_{ph} I_{ph} \cos\phi$$

or

$$P = 4.25 V_L I_L \cos\phi$$

C. Comparison between Three-Phase & Five-Phase Supply

Three-Phase Voltage relation:

$$V_L = \sqrt{3} V_{ph} \text{ or } V_L = 1.73 V_{ph}$$

Five-Phase Voltage relation:

$$V_L = \sqrt{1.38} V_{ph} \text{ or } V_L = 1.17 V_{ph}$$

Three-Phase Current relation:

$$I_L = I_{ph}$$

Five-Phase Current relation:

$$I_L = I_{ph}$$

Three-Phase Power (in the case of balanced system):

$$P = \sqrt{3} V_L I_L \cos\phi \text{ or } P = 1.73 V_L I_L \cos\phi$$

Five-Phase Power (in the case of balanced system):

$$P = 5 V_{ph} I_{ph} \cos\phi \text{ or } P = 4.25 V_L I_L \cos\phi$$

So, the five-phase power is more than the three-phase power, i.e., five-phase power is 2.52 times more than the three-phase power and 4.25 times more than the single-phase power.

III. FIVE-LEG INVERTER

Single-phase VSIs cover low-range power applications, three-phase VSIs cover the medium- to high-power applications and five-phase VSIs cover above the three-phase power applications. The main purpose of these topologies is to provide a five-phase voltage source, where the amplitude, phase, and frequency of the voltages should always be controllable. Most of the applications require sinusoidal voltage waveforms. The five-phase VSI topology is shown in Fig. 5. As in single-Leg of VSIs, the two switches (S_1 and S_6 , S_3 and S_8 , S_5 and S_{10} , S_7 and S_2 or S_9 and S_4) cannot be switched on at a time, because this would result in a short circuit across the dc link voltage supply. Similarly, in order to avoid undefined states in the VSI, and thus undefined ac output line voltages, the switches of any leg of the inverter cannot be switched off simultaneously as this will result in voltages that will depend upon the respective line current polarity.

The circuit totally explained with six steps. During step-1, $0 \leq \omega t < \pi/5$, switches conducting 1, 8, 10, 7, 9. It is shown Fig. 6. All impedances are same and Z_1, Z_4, Z_5 are parallel having +ve sign and Z_2, Z_3 are parallel having -ve sign. The above two combinations are in series each other.

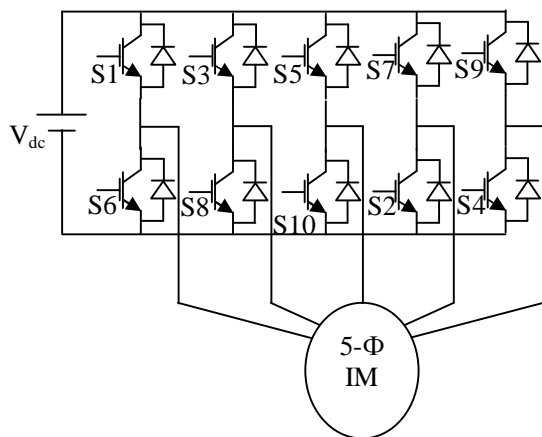

Fig. 5 Five Phase/Leg Inverter Topology.

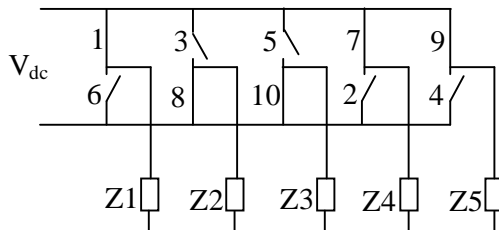

Fig. 6 Equivalent Circuit for switching.

Current, $i_1 = \frac{V_s}{5z/6} = \frac{6}{5} * \frac{V_s}{z}$

Phase Voltages,

$v_{ao} = v_{do} = v_{e0} = i_1 * \frac{z}{3} = \frac{2}{5} V_s$

$v_{ob} = -v_{bo} = v_{oc} = -v_{co} = i_1 * \frac{z}{2} = -\frac{3}{5} V_s$

Similarly, step - 2; $\pi/5 \leq \omega t \leq 2\pi/5$

Current, $i_2 = \frac{V_s}{5z/6} = \frac{6}{5} * \frac{V_s}{z}$

Phase voltages,

$v_{bo} = v_{co} = v_{d0} = -\frac{2}{5} V_s$

$v_{ao} = v_{eo} = \frac{3}{5} V_s$

Step - 3; $2\pi/5 \leq \omega t \leq 3\pi/5$

Current, $i_3 = \frac{V_s}{5z/6} = \frac{6}{5} * \frac{V_s}{z}$

Phase voltages,

$v_{ao} = v_{bo} = v_{e0} = \frac{2}{5} V_s$

$v_{co} = v_{do} = -\frac{3}{5} V_s$

Step - 4; $3\pi/5 \leq \omega t \leq 4\pi/5$

Current, $i_4 = \frac{V_s}{5z/6} = \frac{6}{5} * \frac{V_s}{z}$

Phase voltages,

$v_{co} = v_{do} = v_{e0} = -\frac{2}{5} V_s$

$v_{ao} = v_{bo} = \frac{3}{5} V_s$

Step - 5; $4\pi/5 \leq \omega t \leq \pi$

Current, $i_5 = \frac{V_s}{5z/6} = \frac{6}{5} * \frac{V_s}{z}$

Phase voltages,

$v_{ao} = v_{bo} = v_{e0} = \frac{2}{5} V_s$

$v_{do} = v_{eo} = -\frac{3}{5} V_s$

Step - 6; $\pi \leq \omega t \leq 6\pi/5$

Current, $i_6 = \frac{V_s}{5z/6} = \frac{6}{5} * \frac{V_s}{z}$

Phase voltages,

$v_{ao} = v_{do} = v_{e0} = -\frac{2}{5} V_s$

$v_{bo} = v_{co} = \frac{3}{5} V_s$

The governing phasor equations for five phase supply are

$$\begin{bmatrix} V_a \\ V_b \\ V_c \\ V_d \\ V_e \end{bmatrix} = \frac{1}{\sin\left(\frac{\pi}{3}\right)} * \begin{bmatrix} \sin\left(\frac{\pi}{3}\right) & 0 & 0 \\ 0 & \sin\left(\frac{\pi}{15}\right) & -\sin\left(\frac{4\pi}{15}\right) \\ -\sin\left(\frac{2\pi}{15}\right) & \sin\left(\frac{\pi}{5}\right) & 0 \\ -\sin\left(\frac{2\pi}{15}\right) & 0 & \sin\left(\frac{\pi}{5}\right) \\ 0 & -\sin\left(\frac{4\pi}{15}\right) & \sin\left(\frac{\pi}{15}\right) \end{bmatrix} \begin{bmatrix} V_x \\ V_y \\ V_z \end{bmatrix}$$

$V_a = V_{max} \sin(\omega t)$

$V_b = V_{max} \sin\left(\omega t + \frac{2\pi}{5}\right)$

$V_c = V_{max} \sin\left(\omega t + \frac{4\pi}{5}\right)$

$V_d = V_{max} \sin\left(\omega t - \frac{4\pi}{5}\right)$

$V_e = V_{max} \sin\left(\omega t - \frac{2\pi}{5}\right)$

$V_x = V_{max} \sin(\omega t)$

$V_y = V_{max} \sin\left(\omega t + \frac{2\pi}{3}\right)$

$V_z = V_{max} \sin\left(\omega t - \frac{2\pi}{3}\right)$

$$\begin{bmatrix} V_x \\ V_y \\ V_z \end{bmatrix} = \frac{1}{\sin\left(\frac{2\pi}{5}\right)} * \begin{bmatrix} \sin\left(\frac{2\pi}{5}\right) & 0 & 0 & 0 & 0 \\ 0 & \sin\left(\frac{2\pi}{15}\right) & \sin\left(\frac{4\pi}{15}\right) & 0 & 0 \\ 0 & 0 & 0 & \sin\left(\frac{4\pi}{15}\right) & \sin\left(\frac{2\pi}{15}\right) \end{bmatrix} \begin{bmatrix} V_a \\ V_b \\ V_c \\ V_d \\ V_e \end{bmatrix}$$

Angle in Degrees	0°	36°	72°	108°	144°	180°	216°	252°	288°	324°	360°	
Leg-1	S1					S6						
Leg-2	S8	S3				S8						
Leg-3	S10				S5				S10			
Leg-4	S7	S2				S7						
Leg-5	S9			S4						S9		

Conducti on period	Step-I	Step-II	Step-III	Step-IV	Step-V	Step-VI
	$0 \leq \omega t < \pi/5$	$\pi/5 \leq \omega t < 2\pi/5$	$2\pi/5 \leq \omega t < 3\pi/5$	$3\pi/5 \leq \omega t < 4\pi/5$	$4\pi/5 \leq \omega t < \pi$	$\pi \leq \omega t < 6\pi/5$
	1,8,10,7,9	1,8,10,2,9	1,3,10,2,9	1,3,10,2,4	1,3,5,2,4	6,3,5,2,4

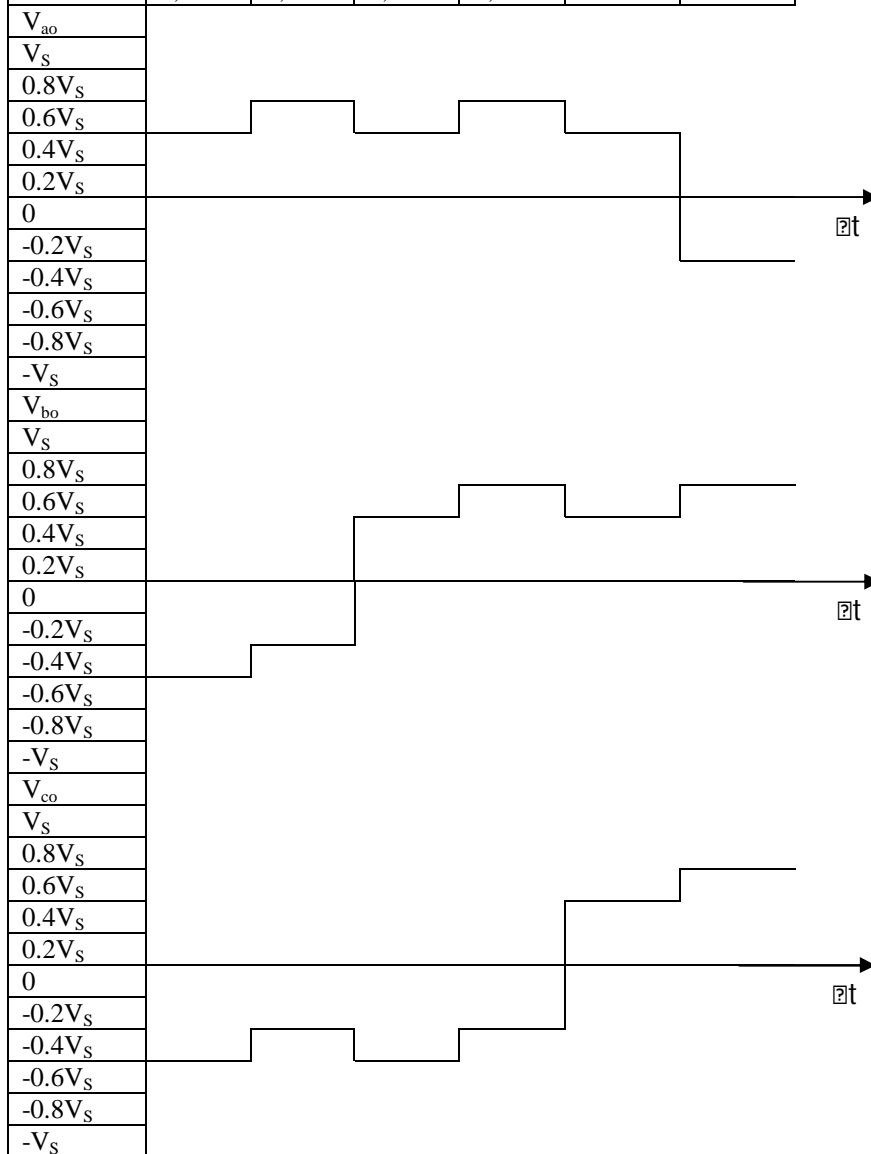

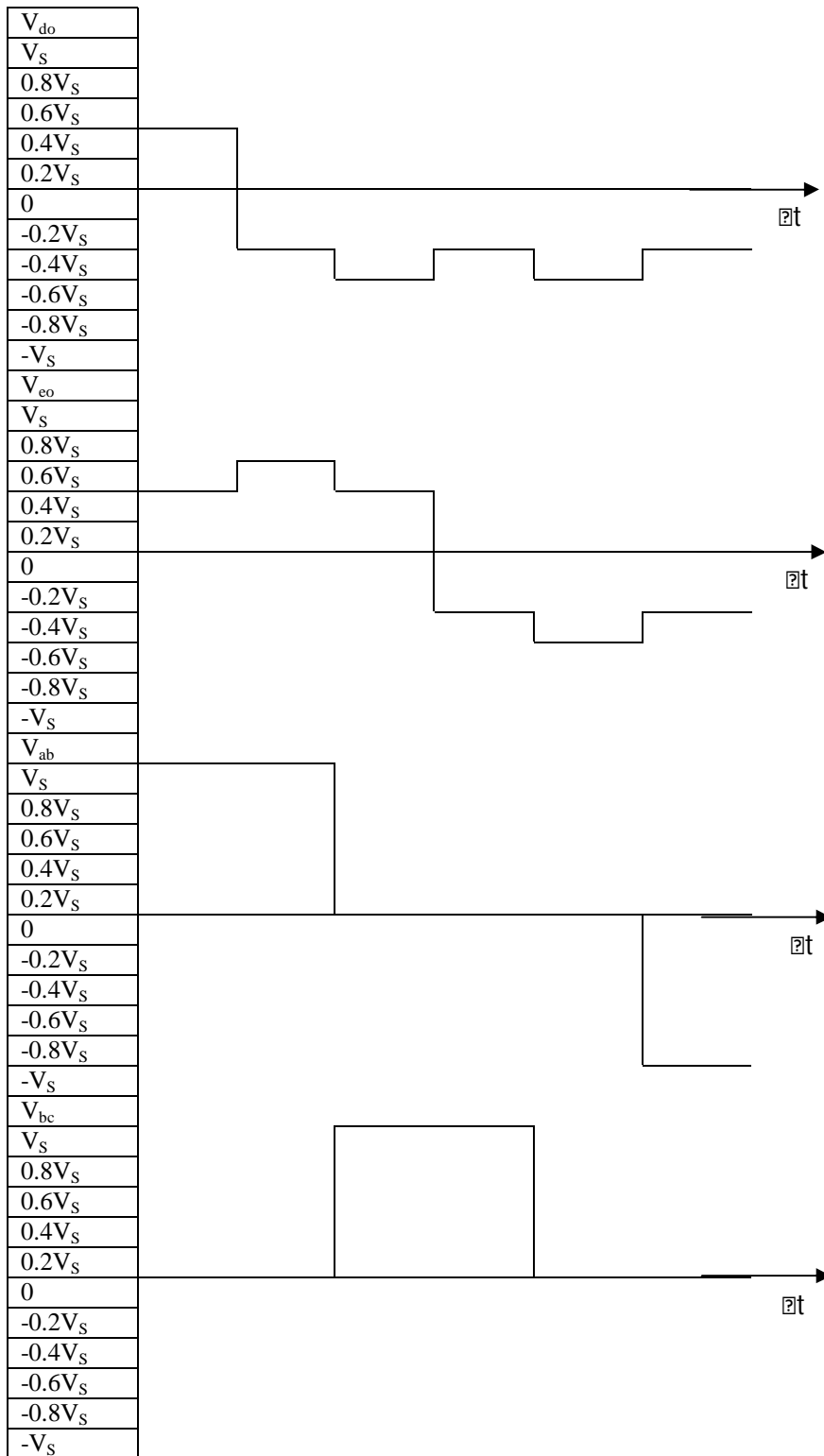

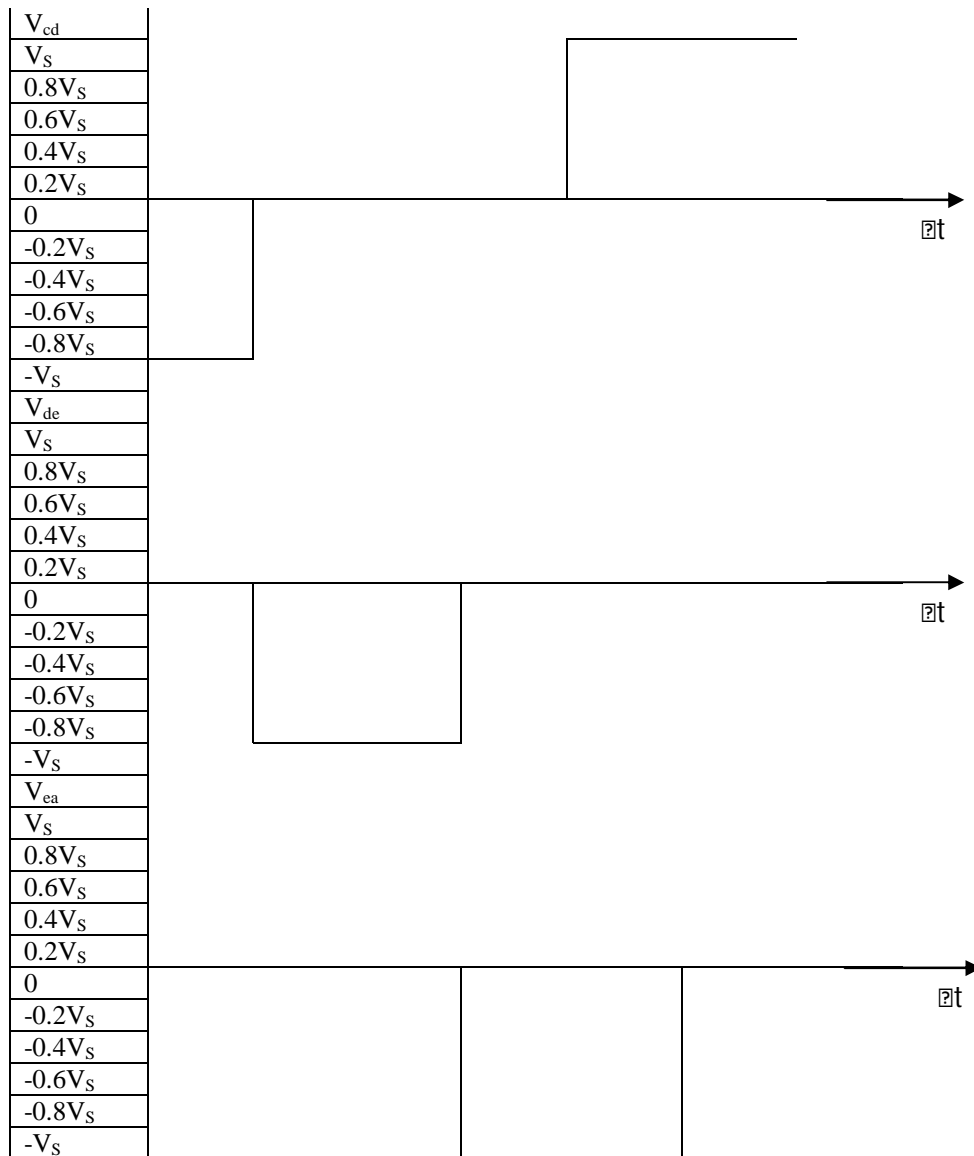

Fig. 7 Voltage waveforms for 180⁰ mode 5-phase VSI

IV. SIMULATION RESULTS

The five leg inverter is at first simulated by using “simpowersystem” block sets of the Matlab/Simulink software. The inbuilt IGBT/Diode blocks are used to simulate. The appropriate gate pulses are set by PWM technique and the simulation is run. Brief output voltage description for the five

leg inverter is shown below. The simulation model is depicted in Fig. 8 and the resulting input and output voltage waveforms are illustrated in Fig. 9, 10 & 11. It is clearly seen that the output is a balanced five-phase supply for a DC supply. There was no earth current flowing when neutral earthed at load side. The output currents with voltage waveforms are shown in Fig. 9, 10, & 11.

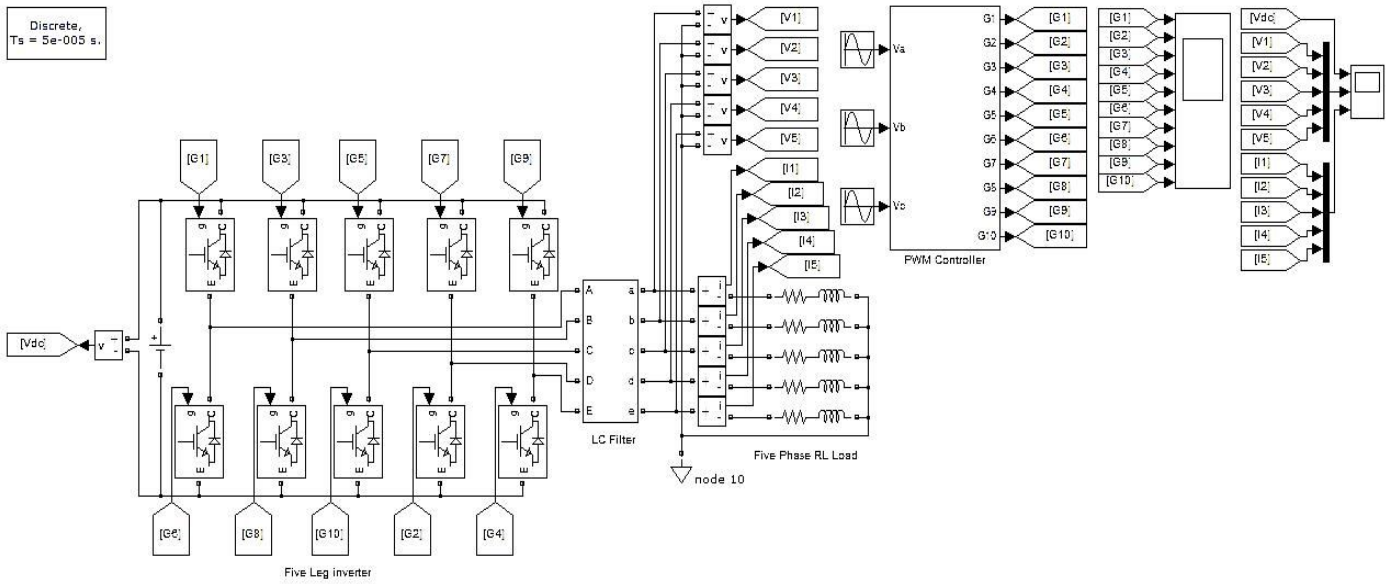

Fig. 8 Simulation Diagram for Five-Leg Inverter

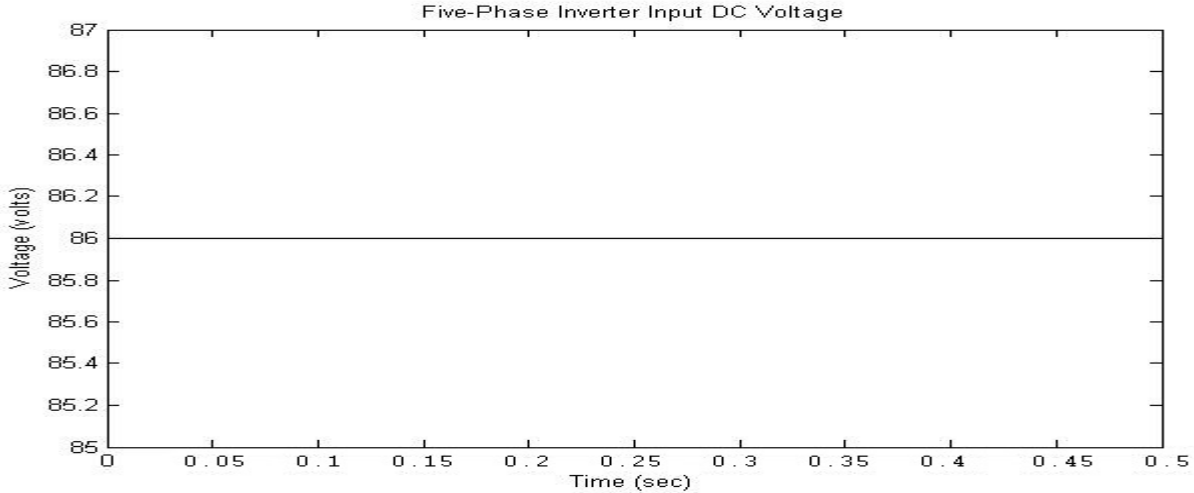

Fig. 9 Five-Leg Inverter DC Input Voltage

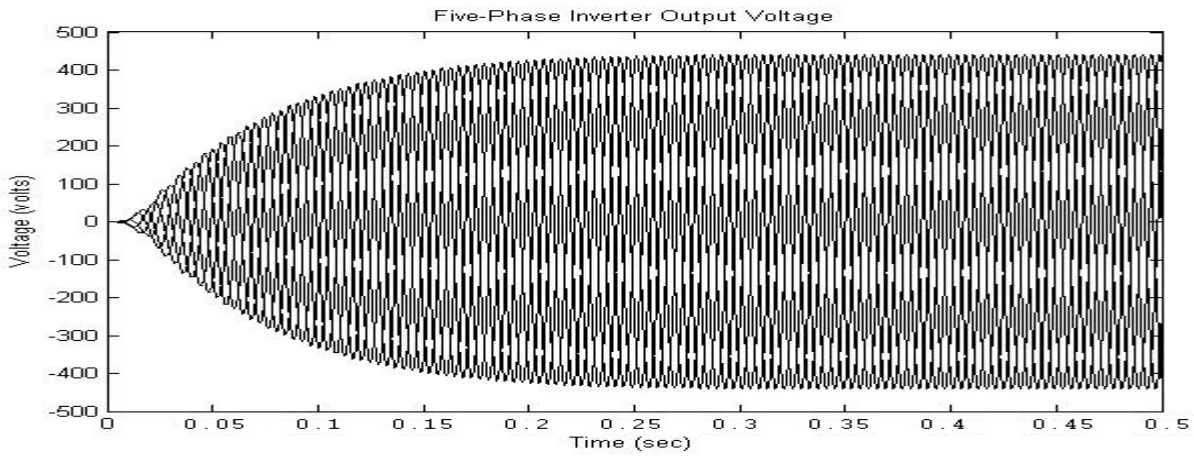

Fig. 10 Five-Leg Inverter Five-Phase Output Voltage

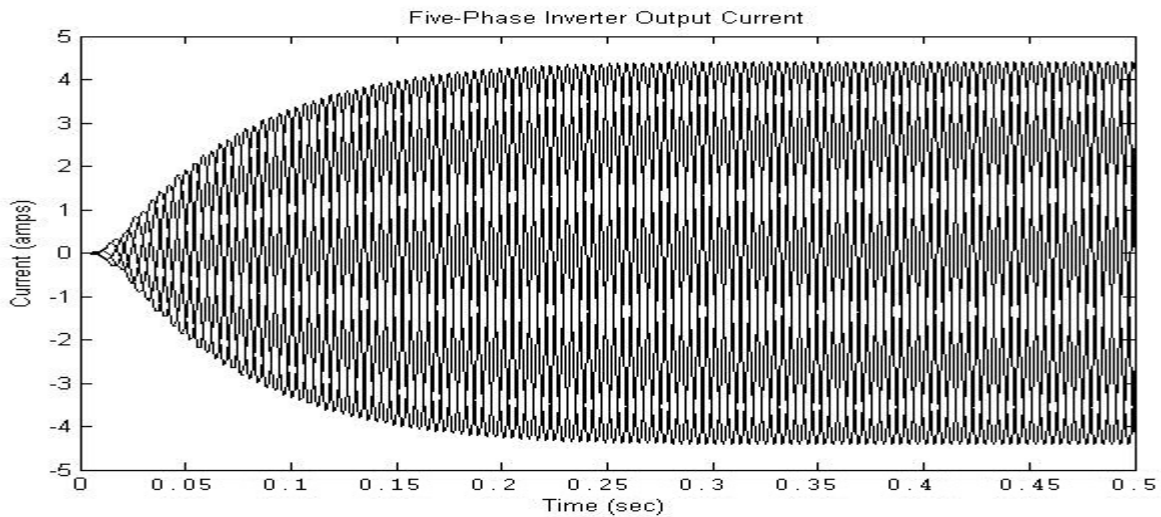

Fig. 11 Five-Leg Inverter Five-Phase Output Current

V. CONCLUSION

This paper proposes a new five leg inverter connection scheme to invert the three-phase grid power (it is convert by rectifier as DC)/DC to a five-phase output supply. The connection scheme and relation between input and output are illustrated. The successful implementation of the proposed connection scheme is elaborated by using simulation. It is expected that the proposed connection scheme can be used in drives applications and may also be further explored to be utilized in multiphase power transmission systems. From the application point of view it is suitable, driven the Five Phase IM as ripple free torque and variable speeds are also available by varying the switching frequency. This inverter scheme is

12. THD is 0.43% acceptable. Fig. 13 shows the list type analysis for total harmonic distortion. In this the circular spot shows the third harmonic percentage include at the output side. Switching frequency is 2000 Hz. The five phase power is 2.52 times more than the three phase power and 4.25 times more than the single phase power.

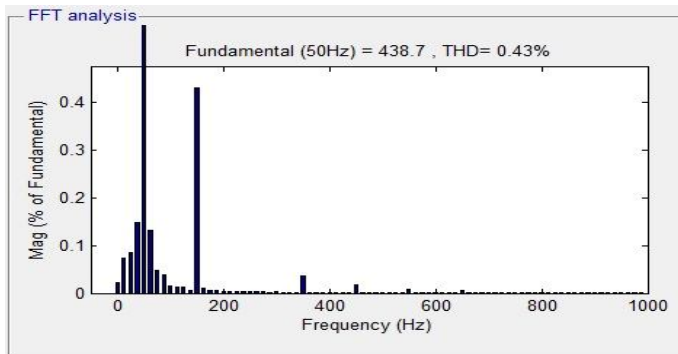

Fig. 12 Total Harmonic Distortion with bar type analysis

cheaper, because the IGBT cost and PWM technique control scheme setup kit is very cheaper. The five leg inverter Total Harmonic Distortion (THD) with bar type analysis is shown Fig.

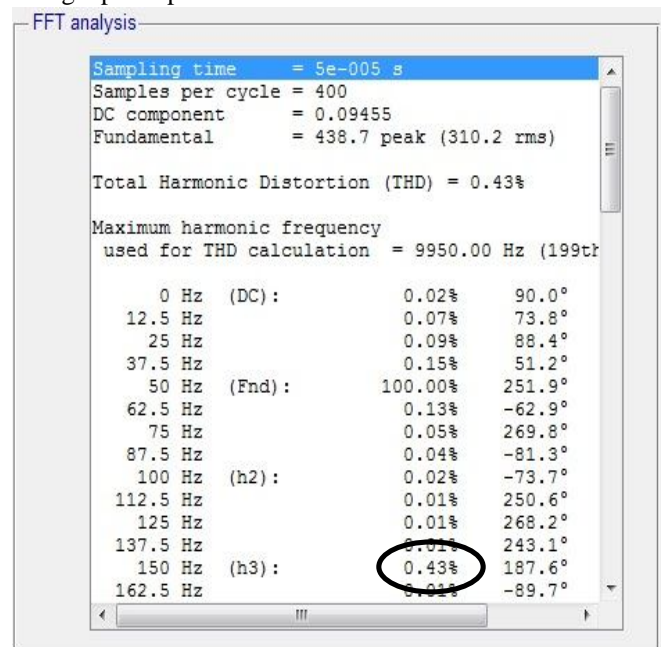

Fig. 13 Total Harmonic Distortion with list type Analysis

ACKNOWLEDGMENT

It is our sincere obligation to thank our well-wishers Dr. M. Venu Gopala Rao, Ph.D. EEE HOD, Mr. D. Seshi Reddy, M.Tech. (Ph.D.), Associate Professor & Mrs. S.V.N.L. Lalitha, Associate Professor in KL University at Vaddeswaram, Guntur Dist.

REFERENCES

- [1] E. E. Ward, and H. Harer, Dipl.-Ing, "Preliminary investigation of an inverter – fed 5 – phase induction motor," Proc. Inst. Elect. Eng., vol. 116, no.6, 1969.
- [2] Duro Basic, Jain Guo Zhu, Gerard Boardman, "Transient performance study of brushless doubly fed twin stator generator," IEEE Trans. Energy convers., vol. 8, no. 3, pp. 400-408, July 2003.
- [3] G. K. Singh, "Self excited induction generator research – a survey," Elect. Power syst. Res., vol. 69, pp. 107 – 114, 2004.
- [4] S. Singaravelu, S. Sasikumar, "A novel steady state modeling and analysis of six-phase self-excited induction generators for renewable energy generation," International Journal of Emerging Electrical Power Systems, vol. 12, Issue 5, Article 7, 2011.
- [5] G. K. Singh, K. B. Yadav, R. P. Saini, "Analysis of a saturated multi-phase (six-phase) self-excited induction generator," International Journal of Emerging Electric Power systems, vol. 7, Issue 2, Article 5, 2006.
- [6] A. Zakir Husain, B. Ravindra Kumar Singh, and C. Shri Niwas Tiwari, "Multi-phase (6-Phase & 12-Phase) Transmission Lines: Performance Characteristics," International Journal of Mathematics and Computers in Simulation, Volume 1, Issue 2, 2007, pp. 150 – 159.
- [7] P. PAO-LA-OR, A. Isaramongkolark, T. Kulworawanichpang, "Electromagnetic field distribution of phase-sequence orientation of a double-circuit power transmission line based on finite element method," WSEAS Transactions on power systems, vol. 3, Issue 10, October 2008, pp. 653-663.
- [8] G. K. Singh, V. Panty Y. P. Singh, "Voltage source inverter driven multi-phase induction machine," Computers and Electrical Engineering 29 (2003), pp. 813-834.
- [9] K. N. Pavithran, R. Parimelalagan, and M. R. Krihnamurthy, "Studies on inverter - fed five - phase induction motor drive," IEEE Transactions on Power Electronics, vol. 3, no. 2, April 1988, pp. 224 – 235.
- [10] Friedrich W. Fuchs, "Some diagnosis methods for voltage source inverters in variable speed drives with induction machines a survey," 2003 IEEE, pp. 1378 – 1385.
- [11] Paul C. Krause, and Thomas A. Lipo, "Analysis and simplified representations of a rectifier – inverter induction motor drive," IEEE Transactions on Power Apparatus and systems, vol. pas – 88, no. 5, may 1969, pp. 588 – 596.
- [12] Edward P. Cornell, and Thomas A. Lipo, "Modeling and Design of Controlled Current Induction Motor Drive Systems," IEEE Transactions on Industry Applications, vol. IA-13, NO. 4, JULY/AUGUST 1977, pp. 321 - 330.
- [13] K. N. Pavithran, R. Parimelalagan, G. Sridhara Rao, Prof. J. Holtz, DrIng, "Optimum design of an induction motor for operation with current source inverters," IEEE PROCEEDINGS, Vol. 134, Pt. B, No. 1, JANUARY 1987.
- [14] Emil Leni, Martin Jones, Slobodan N. Vukosanic, and Hamid A. Toliyat, "A Novel concept of a multiphase, multimotor vector controlled drive system supplied from a single voltage source inverter," IEEE Transaction on Power Electronics, vol.19, no.2, march 2004, pp. 320 - 335.
- [15] Dong Liu, Jia-Q Yang, Jin Huang *, Hai-bo Jiang, "Realization of a SPWM inverter for multi-phase induction motor drives," pp. 1287 – 1290.
- [16] D. Casadei, M. Mengoni, G. Serra, A. Tani, L. Zarri, Bologna, Italy, "Comparison of Different Fault-Tolerant Control Strategies for Seven-Phase Induction Motor Drives".
- [17] Drazen Dujic, Martin Jones, and Emil Levi, "Analysis of Output Current-Ripple RMS in Multiphase Drives Using Polygon Approach," IEEE Transactions on Power Electronics, vol. 25, no. 7, JULY 2010, pp. 1838 – 1849.
- [18] A. N. Arvindan and P. Pushpakarthick, "24 - Pulse Rectifier Realization by 3-Phase to Four 3-Phase Transformation using Conventional Transformers," NPEC-2010, pp. 1 – 8.
- [19] Vipin Garg, Bhim Singh, G. Bhuvaneshwari, "A tapped star connected autotransformer based 24-pulse AC-DC converter for power quality improvement in induction motor drives," International Journal of Emerging Electric Power Systems, vol. 7, Issue 4, Article 2, 2006.
- [20] Bhim Singh, Vipin Garg, Gurumoorthy Bhuvaneshwari, "A 24-pulse AC-DC converter employing a pulse doubling technique for vector-controlled induction motor drives."
- [21] Bhim Singh, Ganjay Gairole, "An autotransformer – based 36 – pulse controlled AC-DC converter," IETE Journal of research, vol. 54, Issue 4, July-August 2008, pp. 255-263.
- [22] Atif Iqbal, Shaik Moinuddin, M. Rizwan Khan, Sk. Moin Ahmed, and Haithen Abu-Rub, "A Novel Three-Phase to Five-Phase Transformation using a special transformer connection," IEEE Transactions on power delivering, vol. 25, no. 3, JULY 2010, p. no: 1637 – 1644.
- [23] P. C. Krause, "Analysis of electric machinery," Newyork: Mc. Graw-Hill, 1986.