

Temperature and Speed Monitoring System of a DC Motor Using Microcontroller

Priyanka Tupe-Waghmare^{#1}, Gauri Mantri^{*2}

[#]Assistant Professor, E & TC Department, Symbiosis India

Abstract— The system is proposed mainly to automate test equipment used for ‘temperature and speed monitoring of dc motor ‘and eliminate the need of human assistance and manual intervention. In the system, the speed and temperature of the testing equipment is monitored according to the required specifications and is reset to the initial state using the relay if the temperature exceeds the given threshold. The proposed system notes down all the variations in temperature and speed and the readings are stored in a PC. The 89V51RD2 microcontroller is used to automate the system and the readings are displayed using LED display.

Keywords— Speed Monitoring, DC Motor, micro controller, temperature monitoring.

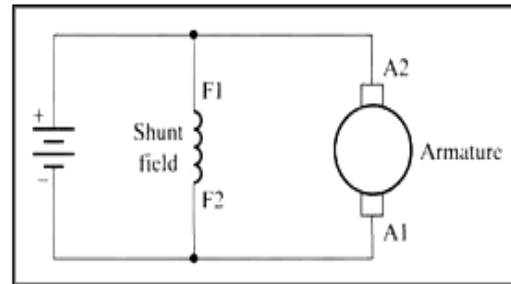

Fig -1: Diagram of Basic DC Motor

The dynamic behavior of the DC motor is described by the following:

$$v = Ri + L \frac{di}{dt} + e_b \quad (1)$$

$$T_m = K_t i_a(t) \quad (2)$$

$$T_m = J \frac{d^2\theta(t)}{dt^2} + B \frac{d\theta(t)}{dt} \quad (3)$$

$$E_b = e_b(t) = K_d \frac{d\theta(t)}{dt} \quad (4)$$

Where, $R = R_a$ = Armature resistance in ohm, L_a = Armature inductance in Henry, i_a = Armature current in ampere, $v = V_a$ = Armature voltage in volts, $e_b = e(t)$ = Back EMF voltage in volts, K_b = back emf constant in volt/(rad/sec), $K_t = K_t$ = torque constant in N-m/Ampere, T_m = torque developed by the motor in N-m, $\theta(t)$ = angular displacement of shaft in radians, J = moment of inertia of motor and load in Kg-m²/rad, B = frictional constant of motor and load in N-m/(rad/sec) [2]

I. INTRODUCTION

Electrical motors are used worldwide. DC or AC motors are used extensively for various kinds of applications like home appliances, electric vehicles, centrifugal pumps, washers etc. Motor converts electrical energy to a mechanical energy. Due to its excessive use in various applications, it is necessary to control the temperature and speed of the motor. [1]

II. WHY IS THIS DEVELOPMENT?

Speed control of the motor is necessary to get a good dynamic response, accuracy and better efficiency whereas temperature control is necessary in low speed applications where motor has to be slowed down as it can get heated up due to extremely high speed. If the temperature rises above or below the ideal range, the results can be harmful-improperly adhered coatings, weakened base material or overall compromised product. The purpose behind the modification of the currently used temperature and speed measurement lies in the fact that manual recording has to face the problems like more amount of time required, availability of skilled labor and uncertainty of workforce to note down the readings accurately. Thus the automation of the entire process helps to counter various drawbacks as mentioned earlier. Moreover, it being a low cost process helps its affordable to small and medium enterprises (SME's) [5]

III. SYSTEM INTRODUCTION

As reference a DC shunt motor is considered which is shown in figure-1. DC shunt motor has field & armature winding in parallel. The current which passes through the field winding & the armature winding are different as they are independent of each other.

Hence the applications that use DC Shunt Motor are generally 5HP or more. [2]

A. Block Diagram

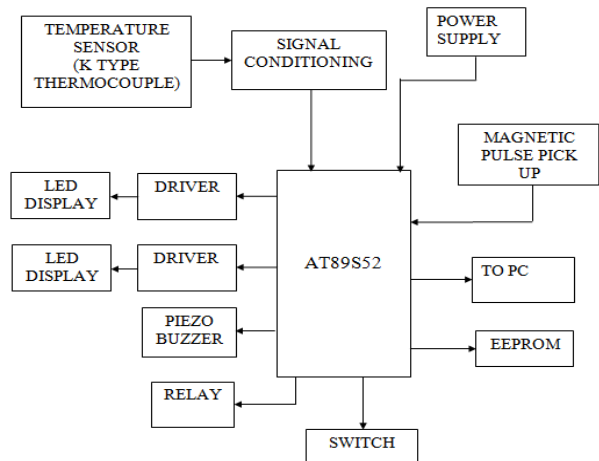

Fig -2: Block Diagram of the Entire System

B. Block Diagram Description

The temperature (in analog form) is sensed by a K Type Thermocouple which consists of two dissimilar metals and produces voltage when temperature varies compared to other parts of the circuit. The signal conditioning circuitry used will convert the analog signal output in a form that is compatible to the ADC. This conditioned analog signal is converted in the digital form by ADC IC MCP3202. Second input i.e. speed is given to the controller in the form of pulses [6]. These pulses are sensed by a 60 teeth magnetic pulse pickup which is used to sense the passing teeth of a motor or a gear. The microcontroller processes the signals which are in the digital form. The Piezoelectric type buzzer is provided to indicate that the temperature is exceeded and the equipment needs to be stopped by the relay. EEPROM IC 24C16 is used to store the set points of the temperature and speed. The connections shown to the PC are used to keep a log of the readings [3][4].

C. Circuit Diagram

The detailed circuit simulation and the interfacing of various devices with the microcontroller is shown in figure 3, 4 & 5. The output signal of the thermocouple is first signal conditioned to take it to a desired level compatible with the ADC. The ADC MCP3202 then converts this analog output voltage into digital one and these data bits are then passed on to the microcontroller port pins P2.1 to P2.3. The measured temperature is then stored in the buffer which is connected with pull up resistors and the output of the buffer are the segments of the LED display. Port pins P1.0 to P1.7 are connected to DISPO to DISP7 signal to drive each common anode display in multiplexing. The watch dog reset IC used to detect X pulses and if these are not present then it resets the controller. The IC 24C16 is an EEPROM IC. It is used to store the set points of the temperature and speed. The buzzer circuitry is used as an indication. If the temperature exceeds then it will be indicated by this buzzer circuitry. Also there are four switches used which are UP, DOWN, PROG and ENTER. The UP and DOWN switches are used for setting the threshold limits for the temperature and the speed which can be incremented and decremented by the help of these switches. The PROG switch is used to start the programming and the ENTER switch is used to enter the values. The relay shown is a SPST, 5V relay which is used to stop the testing equipment in case of over temperature to prevent damage to the motor. The MAX232 is used for serial communication with the PC through the DB9 connector. In the signal conditioning circuit OP07 is adjusted for the gain of 51. The LM324 is used as a unity gain follower. For displaying the current speed, frequency pulses will be taken as input and passed on to the optocoupler and then given to the microcontrollers INTO and INT1 pins which in turn will display the current speed on the LED display.

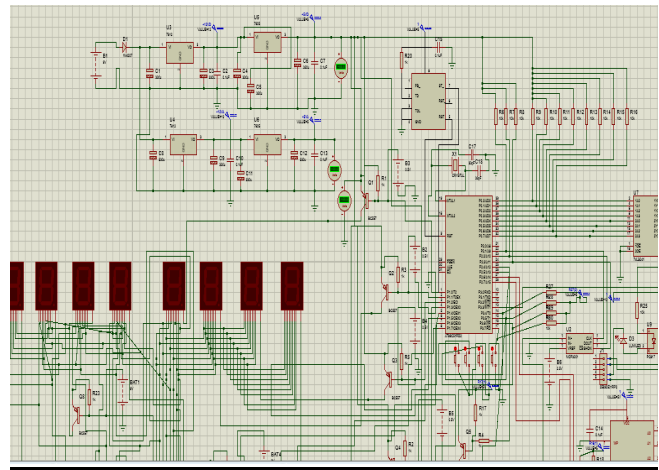

Fig -3: Detailed Circuit Interfacing –I [7][8]

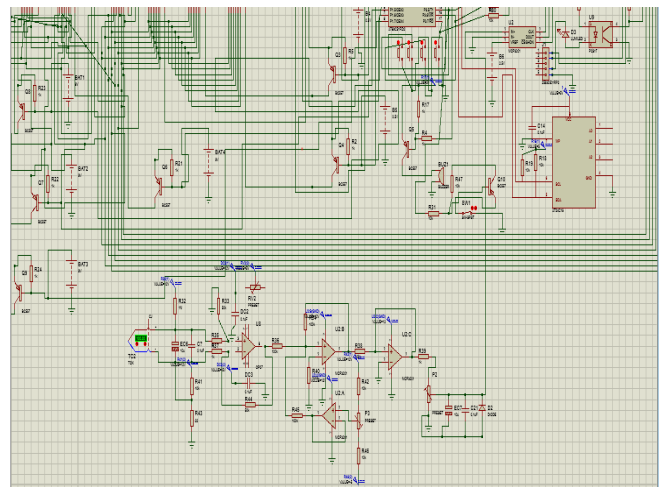

Fig -4: Detailed Circuit Interfacing –II [7][8]

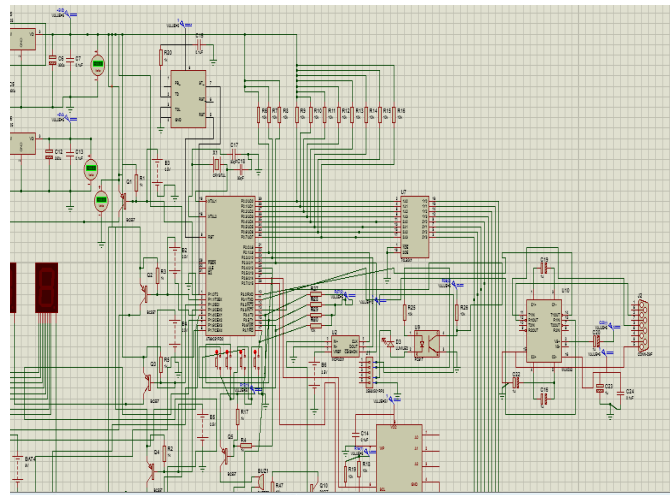

Fig -5: Detailed Circuit Interfacing –III [7][8]

D. Algorithm

1. Start
2. Initialization of external interrupt, timer 0, serial port.
3. Enable timer overflow interrupt.
4. Enable each interrupt source individually.
5. Set the value of interrupt priority register.
6. Initialize the ADC.
7. Display blank led.
8. Call routine of key press.
9. Get a value.
10. Call set parameters routine and store the set parameters in EEPROM
11. Sense the temperature and the speed.
12. If temperature within range calculate and display it.
13. Monitor the temperature and if exceeds the given limit buzzer rings, relay on and shut down the system.
14. Calculate the frequency and display it.
15. Stop.

1. Flow Chart for Speed Monitoring

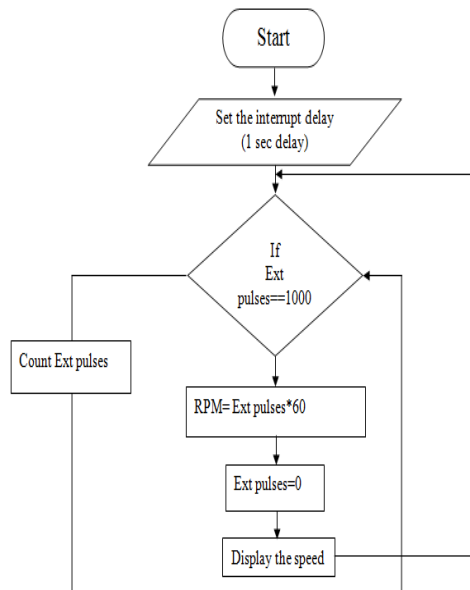

Fig -6: Flow Chart for Speed Monitoring

2. Main Flow Chart

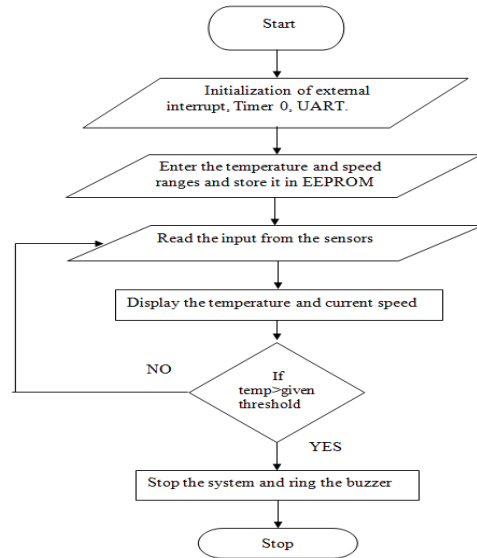

Fig -7: Main Flow Chart

IV. CONCLUSION

The DC motor has been successfully monitored in terms of temperature and speed using microcontroller therefore eliminating the need of human assistance and manual intervention. The proposed system continuously monitors and gives steady response for complicated loads. The log of all the readings is stored in the PC for further reference. In case of extreme readings in terms of temperature and speed, the system will halt the equipment to avoid damage.

REFERENCES

- [1] S|Moleykutty, G. (2008). Speed Control of Separately Excited DC Motor, American Journal of Applied Sciences 5, 227-233
- [2] Neenu Thomas, Dr. P. Poongodi, 2009 Position Control of DC Motor Using Genetic Algorithm Based PID Controller, Proceedings of the World Congress on Engineering 2009 Vol IIWCE 2009, July 1 - 3, 2009, London, U.K.
- [3] Bin Li, Jinhui Lei, "Design of Industrial Temperature Monitoring System Based On Single Chip Microcontroller" Computer Science and Service System (CSS) ,2011 , International Conference on 27-29 June 2011
- [4] Balraj A. Patvardhan A. Renuka Devi V., Aiswarya R., Prasen V "Embedded Temperature Monitoring and Control Unit" Recent Trends in Information, Telecommunication computing (ITC), 2010 International Conference on 12'13 March 2013
- [5] Richard W. Cording, Mishawaka: John C. Teager, Jr., South Bend, "Speed Measurement System", Patent Number-4, 485, 452, Nov. 27, 1984.
- [6] Robert L. Sink, "Speed Measurement and Control", Patent Number-2,876,004, March 3, 1959.
- [7] <http://www.atmel.in/Images/doc1919.pdf>
- [8] [http://powersolutions.danfoss.com/stellent/groups/publications/docume nts/product_literature/bln-95-8980.pdf](http://powersolutions.danfoss.com/stellent/groups/publications/documents/product_literature/bln-95-8980.pdf)